

Rolny

S jednořadým ložiskem - LR.....	4
S dvouřadým ložiskem - LR.....	5
S jehličkovými ložisky - KR.....	7
Vodící rolny s vodící drážkou - R.....	8
Čepy pro vodící rolny - RC.....	9

Rolnickové vedení s AL kolejnicí

Vodící a podpůrné rolny - GD/GS.....	12
Vozíky - GD/GDS.....	13
Momenty a zatížení - GD/GDS.....	14
Kolejnice - GS/GD.....	15
Vodící rolny - RPC/RPE.....	16
Vozíky - C.....	17
Kolejnice - IL.....	17

Rolnickové vedení Systém - V

Vodící rolny - VW.....	20
Čepy - MVB.....	20
Kolejnice - VR.....	21
Příklad montáže a výpočty.....	22

Rolny pro velká zatížení

Podpůrné rolny centrické - HPC.....	26
Podpůrné rolny excentrické - HPCE.....	28
Přírubové rolny centrické - HPJ.....	30
Přírubové rolny excentrické - HPJE.....	32
Vodící rolny centrické - HPV.....	34
Vodící rolny excentrické - HPVE.....	35
Podpůrné rolny bez čepu - HPCA.....	36
Přírubové rolny bez čepu - HPJA.....	37
Vodící rolny bez čepu - HPVA.....	38
Upínací čepy - MSH.....	39
Kolejnice - M.....	40

Kombinované rolny a profily

Pojzdové rolny - HVB.....	42
Upínací desky pro pojezdové rolny - HVP.....	43
Kolejnice - HVR.....	44
Montážní patky pro kolejnice - HVC.....	45

Lineární vedení IBC

Vodící rolny - CBR.....	48
Vozíky - CR/CA.....	49
Kolejnice - LCX, LCU.....	50
Vodící systém - LCE 28.....	51
Vodící systém - LCE 35.....	52
Vodící systém - LCE 43.....	53
Teleskopický vodící systém - LCAE.....	54
Teleskopický vodící systém - LCAD.....	55
Teleskopický vodící systém - LCAH.....	56
Teleskopický vodící systém - LCAZ .E.....	57
Teleskopický vodící systém - LCAZ .D.....	58
Teleskopický vodící systém - LCAS .E.....	59
Teleskopický vodící systém - LCAS .D.....	60

Kolejnicové lineární vedení HIWIN

Miniaturní vedení, úzké provedení – MGN	62
Miniaturní vedení, široké provedení – MGW	63
Kuličkové vedení, úzké provedení – HGH	64
Kuličkové vedení, se sníženou zástavbovou výškou – HGL	65
Kuličkové vedení, přírubové provedení – HGW	66
Kuličkové vedení, úzké provedení – EGH	67
Kuličkové vedení, přírubové provedení – EGW	68
Kuličkové vedení, široké provedení, úzké – WEH	69
Kuličkové vedení, široké provedení, přírubové – WEW	70
Válečkové vedení, úzké provedení – RGH	71
Válečkové vedení, přírubové provedení – RGW	72
Kolejnice pro lineární vedení – R	73

Lineární moduly

Vedení s rolnami a pohonem – GDM	76
Vedení s rolnami a pohonem – GDMLT	77
Vedení s rolnami a pohonem – ILM	78
Lineární modul s rolničkovým vedením a řemenem – TLM65R	79
Lineární modul s kolejnicovým vedením a řemenem – TLM65G	80
Lineární modul s kolejnicovým vedením a kuličkovým šroubem – TLM65V	81
Lineární modul s rolničkovým vedením a řemenem – TLM80R	82
Lineární modul s kolejnicovým vedením a řemenem – TLM80G	83
Lineární modul s kolejnicovým vedením a kuličkovým šroubem – TLM80V	84
Lineární modul s kolejnicovým vedením a řemenem – TLM105G	85
Lineární modul s kolej. vedením a kuličkovým šroubem – TLM105V	86
Posuvové stoly s vodicími tyčemi – STLT	87
Posuvové stoly s kolejnicovým vedením – STLT-G	88
Lineární moduly s kolejnicovým vedením a kuličkovým šroubem – KK	89
Lineární modul s kolejnicovým vedením a kuličkovým šroubem – KK40	90
Lineární modul s kolejnicovým vedením a kuličkovým šroubem – KK50	91
Lineární modul s kolejnicovým vedením a kuličkovým šroubem – KK60	92
Lineární modul s kolejnicovým vedením a kuličkovým šroubem – KK86	94
Lineární modul s kolejnicovým vedením a kuličkovým šroubem – KK100	95

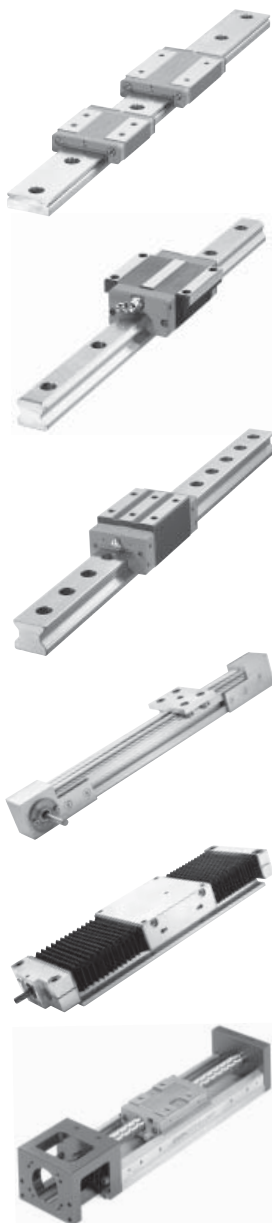

Rolny

S jednořadým ložiskem

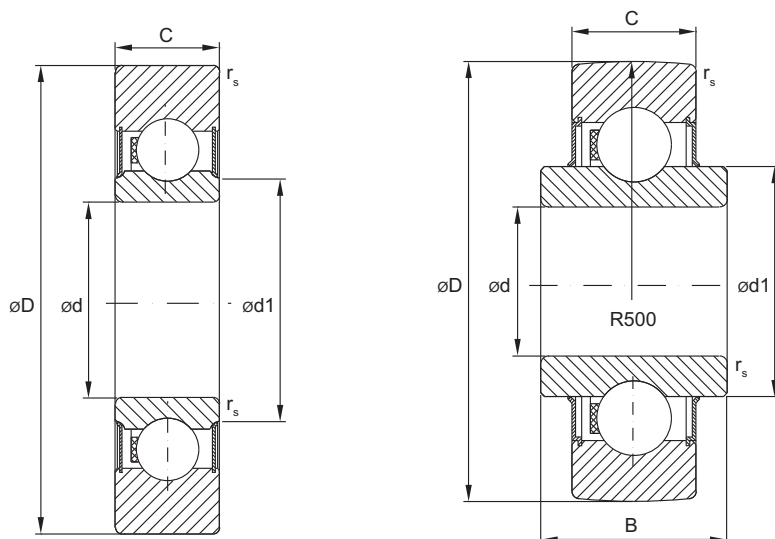

Označení	Rozměry [mm]						Únosnost [N]				Hmotnost [kg]
	$\varnothing d$	$\varnothing D$	C	r_s min	$\varnothing d1$	B	C_d	C_o	F_r perm	F_{or} perm	
LR 200 NPP	10	32	9	0,6	15,4		4200	2050	4100	4100	50
LR 201 NPP	12	35	10	0,6	17,1		5500	2600	4300	5200	50
LR 202 NPP	15	40	11	0,6	20		6700	3150	6300	6300	70
LR 203 NPP	17	47	12	0,6	22,5		9100	4200	8400	8400	110
LR 204 NPP	20	52	14	1	26,5		11800	5400	10200	10700	150
LR 205 NPP	25	62	15	1	30,3		14900	6800	13500	13500	230
LR 206 NPP	30	72	16	1	37,4		20800	9200	18300	18300	330
LR 207 NPP	35	80	17	1,1	42,4		26100	11400	18600	22700	400
LR 209 NPP	45	90	19	1,1	53,2		30300	13100	12700	21700	450
LR 201 RRU	12	35	10	0,6	18,5	15	5500	3000	4300	5200	70
LR 202 RRU	15	40	11	0,6	21,5	14,4	6700	3500	6300	6300	80

S dvouřadým ložiskem

S válcovým vnějším průměrem

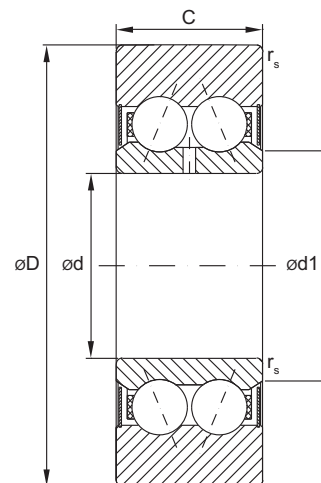

Označení	Rozměry [mm]					Únosnost [N]				Hmotnost [kg]
	ød	øD	C	r _s min	ød1	C _d	C _o	F _{r perm}	F _{or perm}	
LR 5200 KDD	10	32	14	0,6	15,4	6500	3900	7400	7700	70
LR 5201 KDD	12	35	15,9	0,6	17,1	8500	4900	6400	9700	80
LR 5202 KDD	15	40	15,9	0,6	20	10100	5900	10100	11800	110
LR 5203 KDD	17	47	17,5	0,6	22,5	13700	7800	15200	15600	170
LR 5204 KDD	20	52	20,6	1	26,5	17700	10000	13900	20000	230
LR 5205 KDD	25	62	20,6	1	30,3	22000	12400	23800	24700	340
LR 5206 KDD	30	72	23,8	1	37,4	30700	20400	28100	50800	510
LR 5207 KDD	35	80	27	1,1	42,4	39400	21300	27100	42600	660
LR 5208 KDD	40	85	30,2	1,1	48,4	45500	24300	19800	34200	750

S dvouřadým ložiskem

Se zaobleným vnějším průměrem

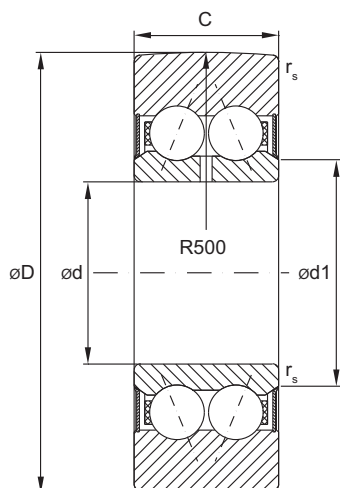

Označení	Rozměry [mm]					Únosnost [N]				Hmotnost [kg]
	ød	øD	C	r _s min	ød1	C _d	C _e	F _r perm	F _{or} perm	
LR 5200 NPPU	10	32	14	0,6	15,4	6500	3900	7400	7700	70
LR 5201 NPPU	12	35	15,9	0,6	17,1	8500	4900	6400	9700	80
LR 5202 NPPU	15	40	15,9	0,6	20	10100	5900	10100	11800	110
LR 5203 NPPU	17	47	17,5	0,6	22,5	13700	7800	15200	15600	170
LR 5204 NPPU	20	52	20,6	1	26,5	17700	10000	13900	20000	230
LR 5205 NPPU	25	62	20,6	1	30,3	22000	12400	23800	24700	340
LR 5206 NPPU	30	72	23,8	1	37,4	30700	20400	28100	50800	510
LR 5207 NPPU	35	80	27	1,1	42,4	39400	21300	27100	42600	660
LR 5208 NPPU	40	85	30,2	1,1	48,4	45500	24300	19800	34200	750
LR 5303 NPPU	17	52	22,2	1	23,5	19300	10600	14800	21100	210
LR 5304 NPPU	20	62	22,2	1,1	29	25100	13800	25700	27600	340
LR 5305 NPPU	25	72	25,4	1,1	34,4	34300	18600	32800	37100	500
LR 5306 NPPU	30	80	30,2	1,1	41,4	47200	25200	41400	50400	670
LR 5307 NPPU	35	90	34,9	1,5	47,7	59800	31400	37600	62700	970
LR 5308 NPPU	40	100	36,5	1,5	52,4	78000	39900	66500	79800	1200

S jehličkovými ložisky

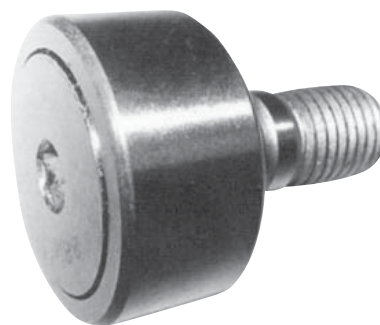
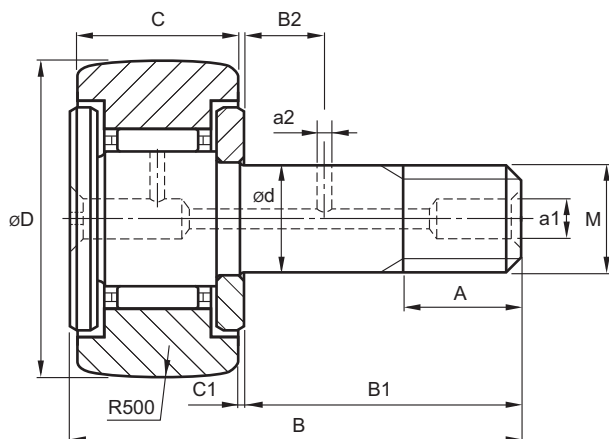

Označení	Rozměry [mm]											Zatížení [kN]		Utahovací moment matice [Nm]	Max. otáčky [rpm]	Hmotnost [kg]
	ød	øD	C	C ₁	B	B ₁	B ₂	M	A	a ₁	a ₂	Dyn.	Stat.			
KR16PP	6	16	11	0,6	28	16,0		M6 × 1	8	4		3,7	4,0	2,5	12000	0,018
KR19PP	8	19	11	0,6	32	20,0		M8 × 1,25	10	4		4,3	6,3	6,8	9000	0,028
KR22PP	10	22	12	0,6	36	23,0		M10 × 1,25	12	4		5,5	6,7	12,5	7000	0,042
KR26PP	10	26	12	0,6	36	23,0		M10 × 1,25	12	4		5,5	6,7	12,5	7000	0,058
KR30PP	12	30	14	0,6	40	25,0	6	M12 × 1,5	13	6	3	8,1	9,0	18,2	5500	0,087
KR35PP	16	35	18	0,8	52	32,5	8	M16 × 1,5	17	6	3	12,3	15,6	45,8	3600	0,169
KR40PP	18	40	20	0,8	58	36,5	8	M18 × 1,5	19	6	3	15,0	25,0	68,7	2900	0,250
KR52PP	20	52	24	0,8	66	40,5	9	M20 × 1,5	21	8	4	21,1	31,4	101,0	2400	0,461
KR62PP	24	62	29	0,8	80	49,5	11	M24 × 1,5	25	8	4	31,1	38,4	205,0	1900	0,815
KR72PP	24	72	29	0,8	80	49,5	11	M24 × 1,5	25	8	4	31,1	38,4	205,0	1900	1,140
KR80PP	30	80	35	1,0	100	63,0	15	M30 × 1,5	32	8	4	46,3	63,0	351,0	1300	1,870
KR85PP	30	85	35	1,0	100	63,0	15	M30 × 1,5	32	8	4	46,3	63,0	351,0	1300	2,030
KR90PP	30	90	35	1,0	100	63,0	15	M30 × 1,5	32	8	4	46,3	63,0	351,0	1300	2,220

Další provedení rolén a excentrické rolny na poptávku.

Vodící rolny s vodící drážkou gotického profilu na vnějším kroužku **série R**

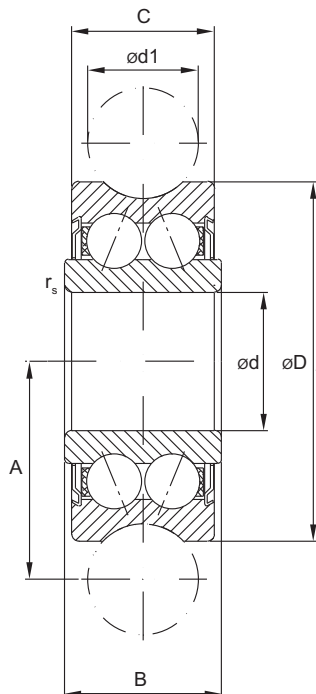

R..ZZ

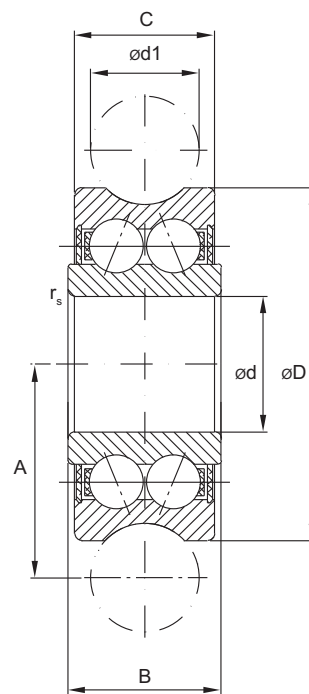

R..2RS

Označení		Rozměry [mm]							Únosnost [N]				Hmotnost [kg]
		ød1	ød	øD	C	B ^{0,12}	A	rs	C _d	C _o	F _{r perm}	F _{or perm}	
R 50/4-4 ZZ	R 50/4-4 2RS	4	4	13	6	7	7,55	0,20	1 050	850	1 150	1 600	7
R 50/5-4 ZZ	R 50/5-4 2RS	4	5	16	7	8	9	0,20	1 200	860	1 300	1 780	9
R 50/5-6 ZZ	R 50/5-6 2RS	6	5	17	7	8	10,5	0,20	1 270	820	1 300	1 780	10
R 50/8-6 ZZ	R 50/8-6 2RS	6	8	24	11	11	14	0,30	3 670	2 280	1 300	4 560	20
R 5201-10 ZZ	R 5201-10 2RS	10	12	35	15,9	15,9	20,65	0,30	8 500	5 100	5 100	10 200	80
R 5301-10 ZZ	R 5201-10 2RS	10	12	42	19	19	24	0,60	13 000	7 700	7 500	14 200	100
R 5302-10 ZZ	R 5302-10 2RS	10	15	47	19	19	26,65	1,00	16 200	9 200	6 200	18 400	170
R 5201-12 ZZ	R 5201-12 2RS	12	12	35	15,9	15,9	21,75	0,30	8 400	5 000	5 100	10 000	85
R 5201-14 ZZ	R 5201-14 2RS	14	12	39,9	18	20	24	0,30	8 900	5 000	6 700	12 100	95
R 5204-16 ZZ*	R 5204-16 2RS*	16	20	52	20,6	22,6	31,5	0,60	16 800	9 500	12 100	16 600	230
R 5206-20 ZZ*	R 5206-20 2RS*	20	25	72	23,8	25,8	41	0,60	29 500	16 600	20 700	33 200	250
R 5206-25 ZZ*	R 5206-25 2RS*	25	25	72	23,8	25,8	43,5	0,60	29 200	16 400	23 100	32 800	250
R 5207-30 ZZ*	R 5207-30 2RS*	30	30	80	27	29	51	1,00	38 000	20 800	21 400	36 200	660
R 5208-40 ZZ*	R 5208-40 2RS*	40	40	98	36	38	62,5	1,00	54 800	29 000	55 000	58 000	1360
R 5308-50 ZZ*	R 5308-50 2RS*	50	40	110	44	46	72,5	1,10	53 000	39 500	69 000	79 000	1400

*Standardně s mazacím otvorem na vnitřním kroužku.

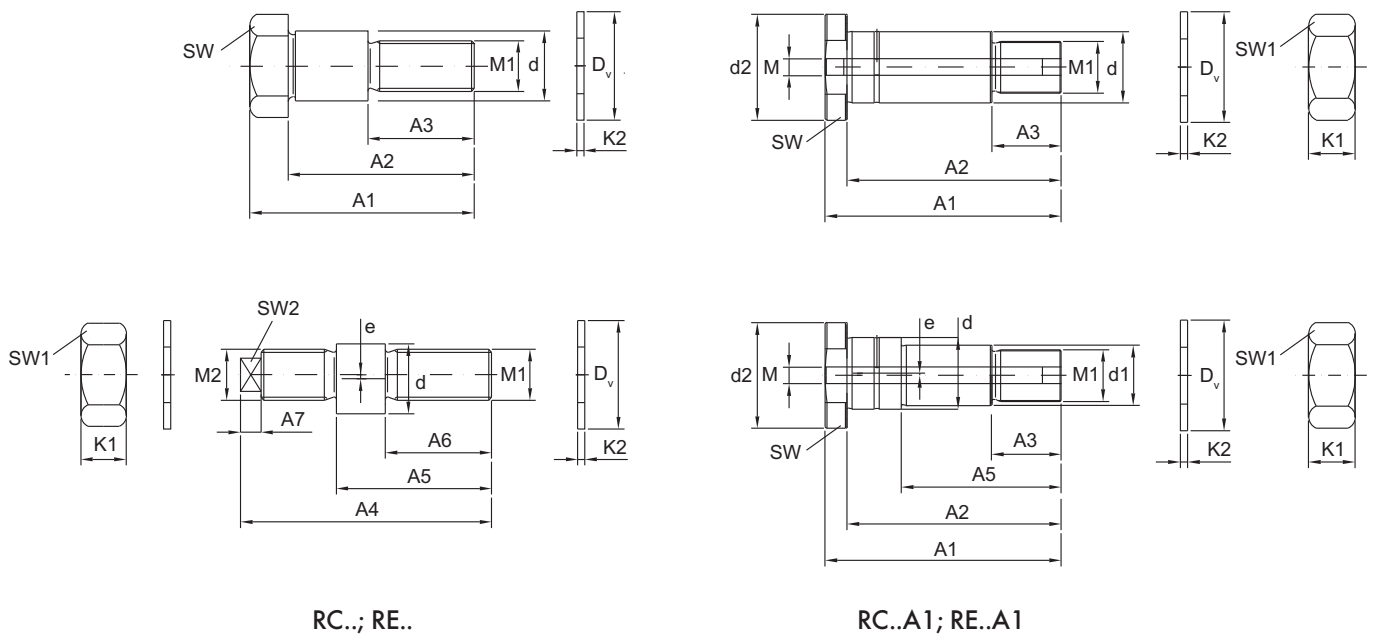

RC.; RE..

RC..A1; RE..A1

Označení		Rozměry [mm]																	Hmot. [kg]				
		A1	A2	A3	A4	A5	A6	A7	d1 ^{h9}	d2	M1	M2	K1	K2	DV	SW	SW1	SW2		e	M		
RC5	RE5-05	19,5	16	9,5	20,5	15	9				M4	M4	2,9			3	7	2	0,5		10		
RC5	RE5-05	19,5	16	9,5	20,5	15	9				M4	M4	2,9			3	7	2	0,5		10		
RC8	RE8-1	28,3	24,3	14	33,2	22	13,7	3,5			M8	M8 × 0,75	4	1	14	13	13	2	1		20		
RC12	RE12-1	43	36	22	50	33,5	19,5	5			M10	M10	8	1,8	21	17	17	5	1		40		
RC12/M12	RE12-1/M12	50,8	43,8	24	57	41	24	5			M12	M12	6,5	1,8	19	17	17	6	1		60		
RC15	RE15-1	50,8	43,8	26	57	41	24	5			M12	M12	6,5	1,8	21	19	19	6	1		60		
RC12 × 45A1	RE12 × 45A1	50	45	16		30			10	20	M10 × 1,5				8	2	21	17	17	6	0,75	5,9	40
RC20 × 67A1	RE20 × 67A1	75	67	23		45			17	30	M16 × 1,5				13	3	30	27	24		1	5,9	200
RC25 × 82A1	RE25 × 82A1	92	82	30		57			22	40	M20 × 1,5				16	3	37	36	30		1	5,9	400
RC25 × 82A1	RE25 × 82A1	92	82	30		57			22	40	M20 × 1,5				16	3	37	36	30		1	5,9	400
RC30 × 95 A1	RE30 × 95 A1	107	95	32		67			27	45	M24 × 1,5				19	4	44	41	36		1	5,9	620
RC40 × 107A1	RE40 × 107A1	117	107	42		72			36	55	M30 × 1,5				24	4	56	46	46		1	5,9	1100
RC40 × 115A1	RE40 × 115A1	125	115	42		72			36	55	M30 × 1,5				24	4	56	46	46		1	5,9	1200

Rolnickové vedení s AL kolejnicí

Z ložiskové oceli 100Cr6
Dvouřadá kuličková ložiska



Vodící rolny vel. 17

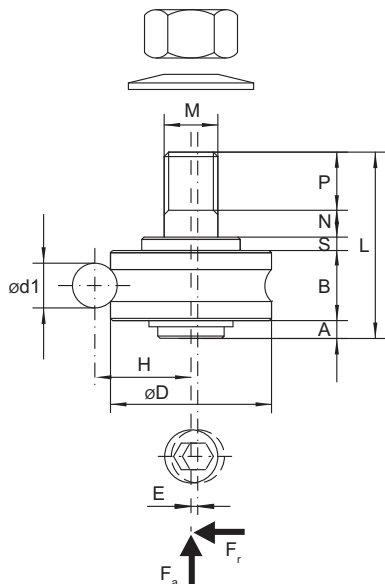

Vodící rolny vel. 22-58

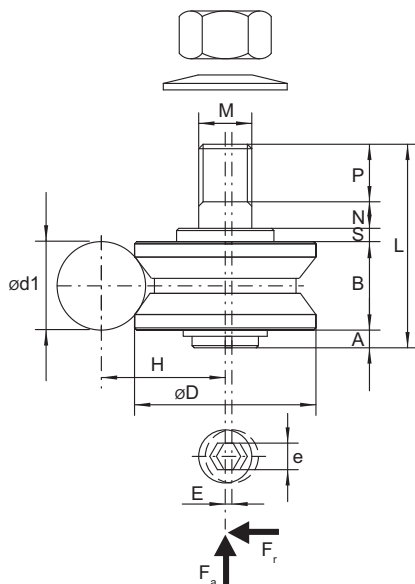

Podpůrné rolny vel. 34-50

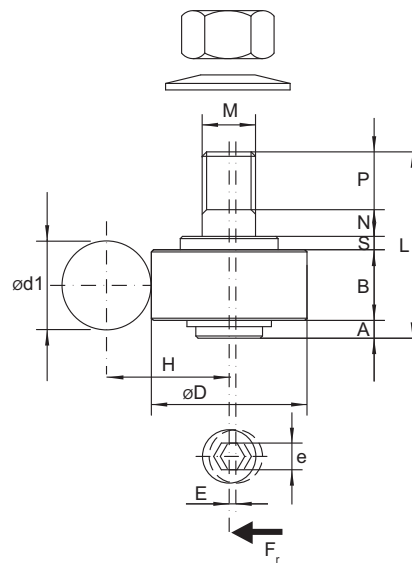

Označ.	Rozměry [mm]												F _a [N]	F _r [N]	Kolejnice	Hmotnost [g]
	A	B	S	N	P	L	M	H	D	E	e	ød1				
Vodící rolny																
17C	2	8	1,5	2,5	4,5	18,5	4	10,5	17			6	256	520	GD6	
17E	2	8	1,5	2,5	4,5	18,5	4	10,5	17	0,5		6	256	520	GD6	
22C	2,5	5,5	2,5	4	5,5	25,5	6	14,5	22		2	10	292	292	GD10/GS10	30
22E	2,5	5,5	2,5	4	5,5	25,5	6	14,5	22	2	2	10	292	292	GD10/GS10	
30C	3	7	2	5	9	33	8	18,3	30		3	10	387	960	GD10/GS10	65
30E	3	7	2	5	9	33	8	18,3	30	2	3	10	387	960	GD10/GS10	
38C	3,5	8,5	2,5	8	12	43	10	22,3	38		5	10	552	1225	GD10/GS10	150
38E	3,5	8,5	2,5	8	12	43	10	22,3	38	2	5	10	552	1225	GD10/GS10	
41C	4	10	2,5	6	13	46	12	28	41		5	20	836	1680	GD20/GS20	165
41E	4	10	3	6	13	46	12	28	41	2	5	20	836	1680	GD20/GS20	
58C	4	12,5	6	11	13	59	16	35	58		6	20	4238	4238	GD20/GS20	430
58E	4	12,5	6	11	13	59	16	35	58	3	6	20	4238	4238	GD20/GS20	
Podpůrné rolny																
34AC	2	17	3	4	15	41	10	22	34		5	10		1300	GD10/GS10	150
34AE	2	17	3	4	15	41	10	22	34	1	5	10		1300	GD10/GS10	150
36AC	0,5	20	3	4	15	42,5	12	28	36		5	10		1600	GD20/GS20	190
36AE	0,5	20	3	4	15	42,5	12	28	36	1	5	10		1600	GD20/GS20	190
50AC	2,5	25	6,5	10	14	58	16	35	50		8	20		3500	GD20/GS20	480
50AE	2,5	25	6,5	10	14	58	16	35	50	1,5	8	20		3500	GD20/GS20	480

Matky a podložky jsou součástí dodávky. Nerezová provedení na poptávku.



Vozík GD je složen z desky z eloxovaného hliníku (na přání z oceli) a z vodících roln 17E a 17C s vodící drážkou s gotickým profilem na vnějším průměru nebo s drážkou tvaru „V“ na vnějším průměru, s úhlem 120°. Dvě rolny jsou na excentrickém a dvě na centrickém čepu.

Vozík GDS je složen z desky z eloxovaného hliníku (na přání z oceli), a vodících roln RPC35 a RPE35 s gotickým profilem na vnějším průměru. Dvě rolny jsou na excentrickém a dvě na centrickém čepu.

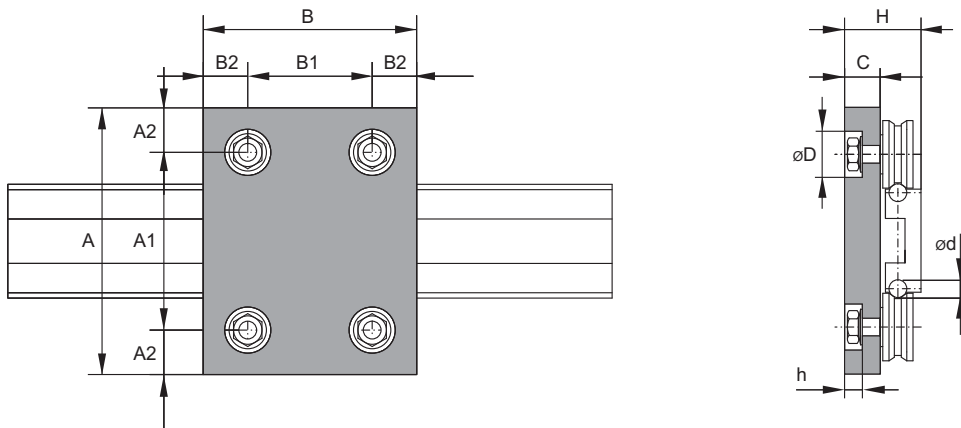

Označení	Rozměry [mm]											Hmotnost [kg]
	A	A1	A2	B	B1	B2	C	H	h	ød ^{b7}	øD	
C6	80	51	14,5	60	31	14,5	8	21	5	6	12	0,18
C10A	120	83	18,5	80	41	19,5	10	31	6	10	16	0,26
C10B	140	90,5	20,75	120	70	25	15	37	10	10	26	0,62
C10C	150	98,5	25,75	120	70	25	20	44	10,5	10	26,5	0,92
C20A	180	126	27	150	90	30	20	51	12	20	30	1,34
C20B	200	142	29	180	100	40	25	61,5	11	20	36	2,64
C20X	300	195	52,5	200	120	40	30	66,5	11	20	36	7,54

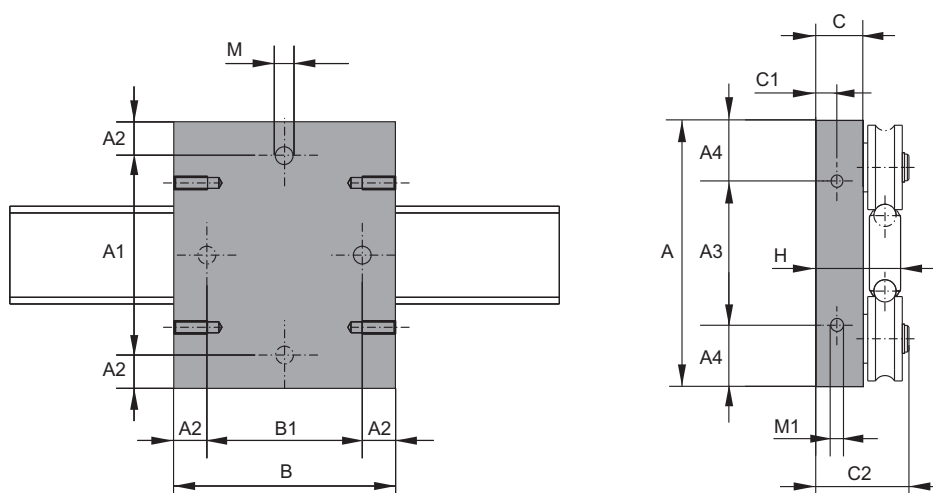

Označení	Rozměry [mm]													Hmotnost [kg]
	A	A1	A2	A3	A4	B	B1	C	C1	C2	H	M	M1	
CS10	120	90	15	65	27,5	100	70	19,3	9,5	40,3	38,2	M10	M6	0,96

Zatížení

Vodící systémy série GD a GS mohou zachytávat zatížení a momenty ve všech směrech.

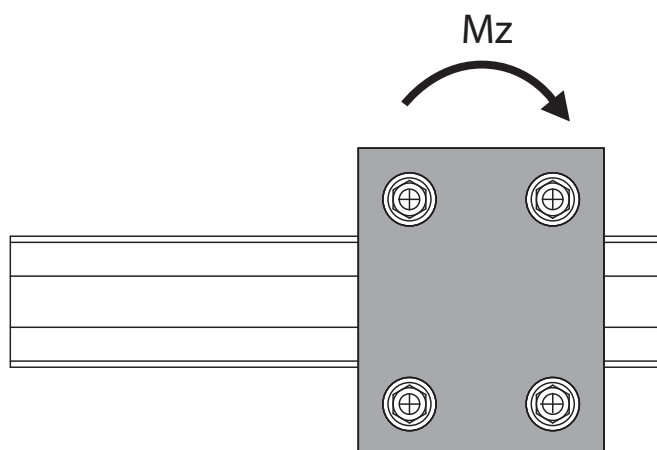
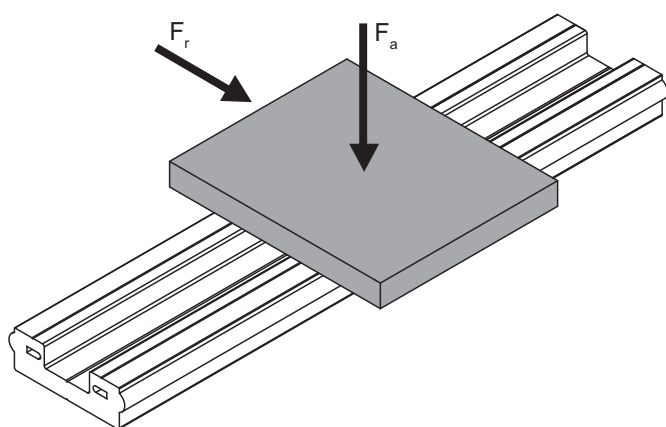
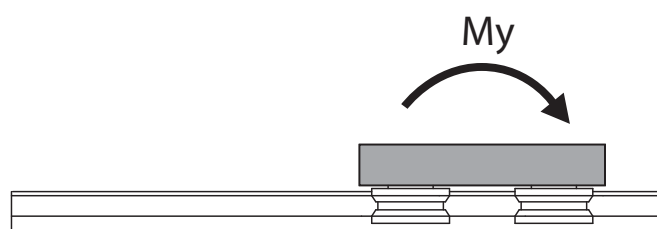
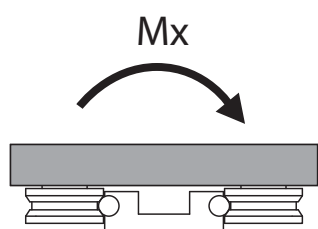

Označení	Max. zatížení [N]		Statický moment [Nm]			Komponenty		
	F_a	F_r	M_x	M_y	M_z	Rolny	Deska	Kolejnice
C6	330	570	20	15	25	17E + 17C	C6-N	GD6
C10A	812	410	48	23	53	22E + 22C	C10A-N	GD10
C10B	1600	1900	69	54	69	30E + 30C	C10B-N	GD10
C10C	2400	2650	108	77	108	38E + 38C	C10C-N	GD10
CS10	1150	2320	77,8	56	111	RPE35 + RPC35	CS10-N	GDS10
C20A	3200	3215	210	150	210	41E + 41C	C20A-N	GD20
C20B	6400	6980	254	320	454	58E + 58C	C20B-N	GD20
C20X	6400	6980	624	384	624	58E + 58C	C20X-N	GDX20

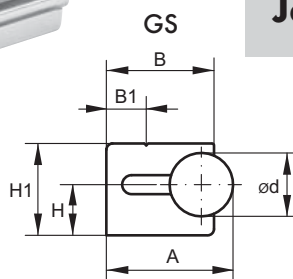

Jednostranné

Označení	Rozměry [mm]						Hmotnost [kg/m]
	ød	H	H1	A	B	B1	
GS10	10	8	14,5	20,5	17	6,3	1,5
GS20	20	15	27	34,2	27	10	3,8

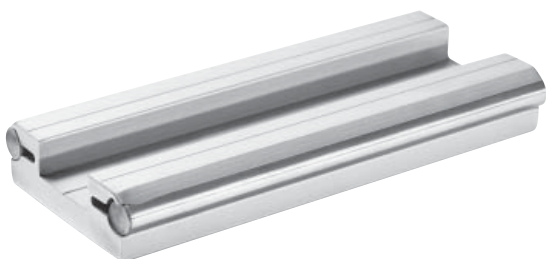

Oboustranné

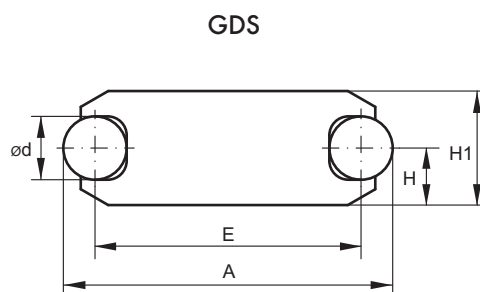
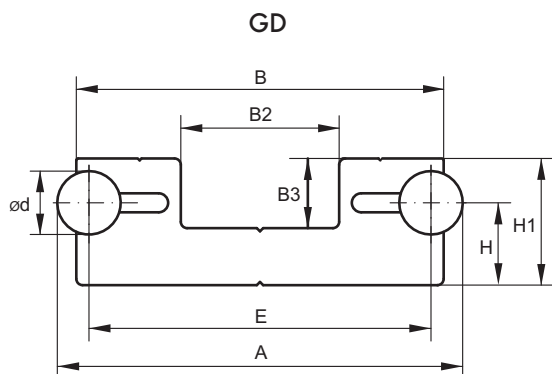

Označení	Rozměry [mm]								Hmotnost [kg/m]
	ød	H	H1	A	B	B2	B3	E	
GD6	6	7,5	12	36	32	14	6	30	1,2
GD10	10	13	20	64	58	25	11	54	3,1
GD20	20	18	30	90	75	20	18	70	8,6
GDX20	20	18	30	145	130	65	18	125	10,9
GDS10	10	9	18	52				42	2,8

Z ložiskové oceli 100Cr6
Gotický profil na vnějším průměru

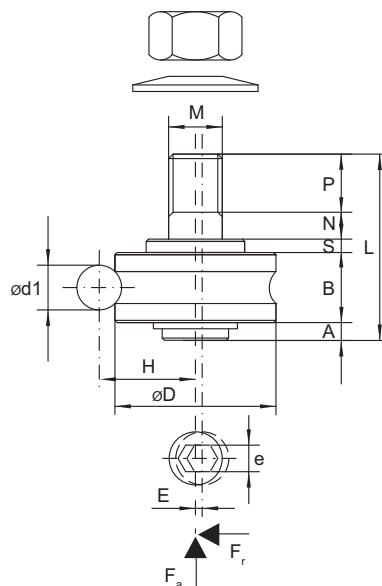

Označ.	Rozměry [mm]												F _a [N]	F _r [N]	Kolejnice	Hmotnost [g]
	A	B	S	N	P	L	M	H	D	E	e	ød1				
RPC17	1,5	8	3	5	5,5	23	5	10,5	17		2,5	6	250	250	IL32	13,4
RPE17	1,5	8	3	5	5,5	23	5	10,5	17	0,5	2,5	6				
RPC24	1,8	11	2	6	7	27,8	8	14	24		4	6	820	1590	IL42	39,2
RPE24	1,8	11	2	6	7	27,8	8	14	24	0,5	4	6				
RPC35	3,1	15,9	2	12	11	44	10	20,6	35		5	10	1090	2390	IL65	112,5
RPE35	3,1	15,9	2	12	11	44	10	20,6	35	0,75	5	10				

Matky a podložky jsou součástí dodávky.

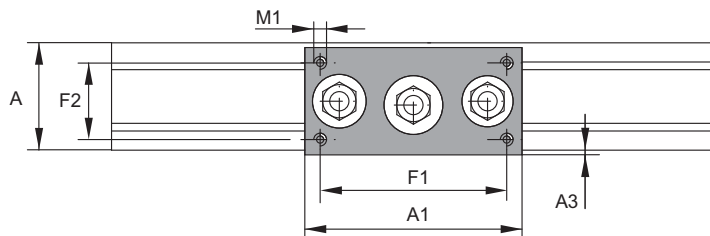
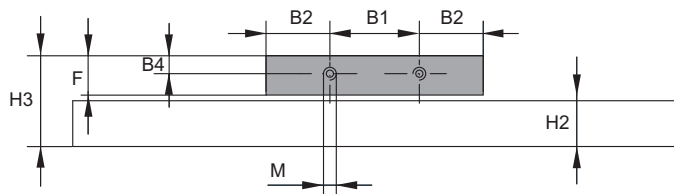

Označení	Rozměry [mm]											Hmotnost [kg]
	A	A1	A3	B1	B2	B4	F	F1	F2	M	M1	
C32	32	65	0,05	24	20,5	5,5	11	57	24	M4	M4	0,15
C42	42	85	1	35	25	7	14	73	30	M5	M5	0,30
C65	65	115	1,2	60	27,5	14	24	95	45	M6	M6	0,80

Zatížení

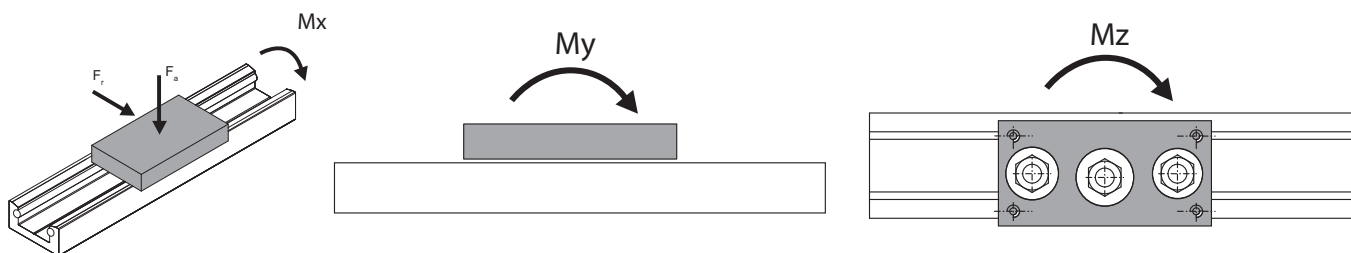

Označení	Max. zatížení [N]		Statický moment [Nm]			Komponenty		
	F _a	F _r	M _x	M _y	M _z	Rolny	Deska	Kolejnice
C32	330	980	3,2	5,2	9	RPE17 + RPC17	C32-N	IL32
C42	500	1680	7,5	14,5	25	RPE24 + RPC24	C42-N	IL42
C65	1160	3930	25,5	44	76	RPE35 + RPC35	C65-N	IL65

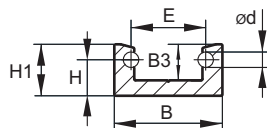

Kolejnice

Označení	Rozměry [mm]						Hmotnost [kg/m]
	ød	H	H1	B	B3	E	
IL32	6	10,5	15,5	32	11	21,5	1,4
IL42	6	14	20	42	14	29	1,6
IL65	10	23,5	32	65	22	42,5	2,0

Rolnickové vedení Systém – V

Dvouřadá ložiska s kosoúhlou styčnou plochou
 ..ZZ – vodící rolna s krycím plechem
 ..2RS – vodící rolna s těsnící pryží

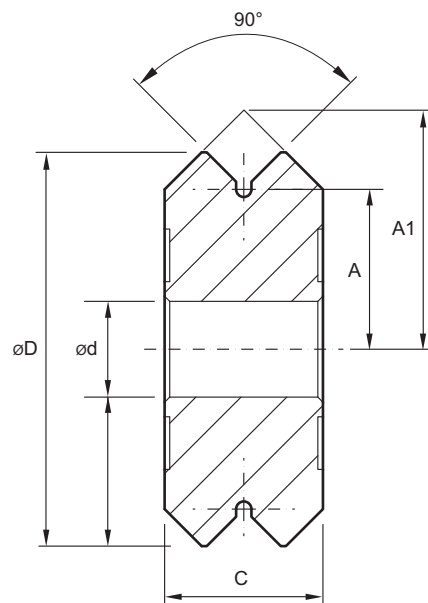
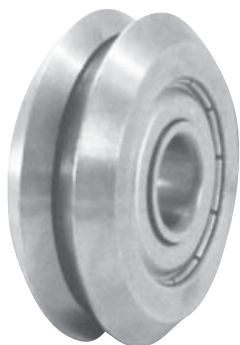

Označení		Rozměry [mm]					Únosnost [kN]		Hmotnost [g]
		ød	øD	C	A	A1	C _d	C _o	
VW 1 ZZ	VW 1 2RS	4,8	19,6	7,9	8	11,9	1	2,2	12
VW 2 ZZ	VW 2 2RS	9,5	30,7	11,1	12,7	18,3	2,5	4,9	40
VW 3 ZZ	VW 3 2RS	12	45,8	15,9	19,1	27	4,9	9,4	136
VW 4 ZZ	VW 4 2RS	15	59,9	19,1	25,4	34,9	8,2	14,8	285

Čepy

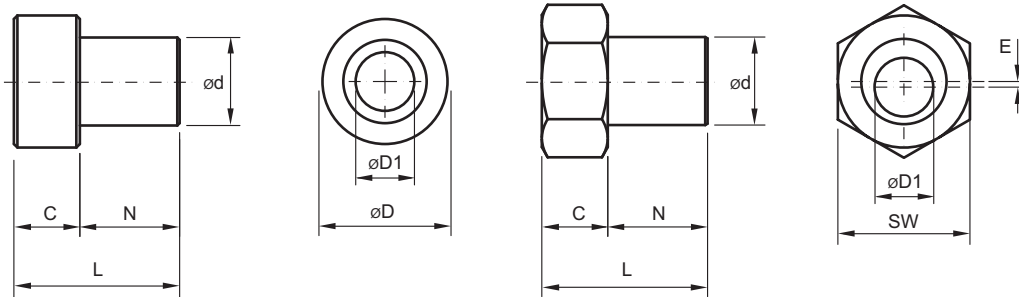
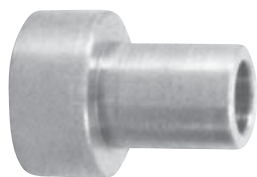

Označení	Rozměry [mm]								Hmotnost [g]
	ød	øD	øD1	C	N	L	E	SW	
MVBC 1	4,76	11,2	3,96	6,2	7,6	13,8			5
MVBE 1	4,76		3,96	6,2	7,6	13,8	0,25	12	5
MVBC 2	9,52	14,2	6	6,7	10,8	17,5			11
MVBE 2	9,52		6	6,7	10,8	17,5	0,61	14	11
MVBC 3	11,99	19,1	8	9,5	15,6	25,1			26
MVBE 3	11,99		8	9,5	15,6	25,1	1,07	19	26
MVBC 4	15	22,4	10	11,1	18,8	29,9			45
MVBE 4	15		10	11,1	18,8	29,9	1,52	22	45

Kolejnice nevrтанé

Materiál CK45 nebo X21Cr13

Max. délka jednoho kusu 6400 mm

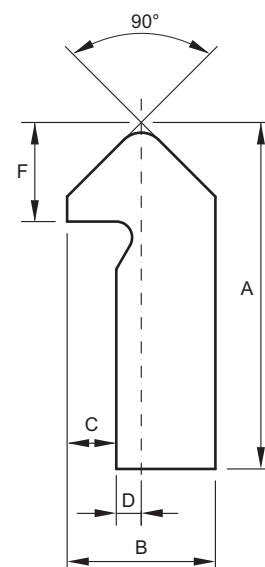
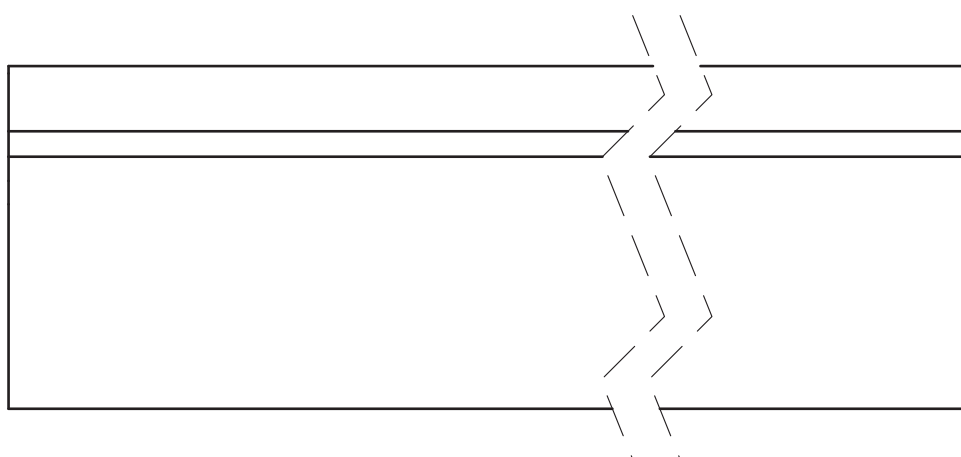
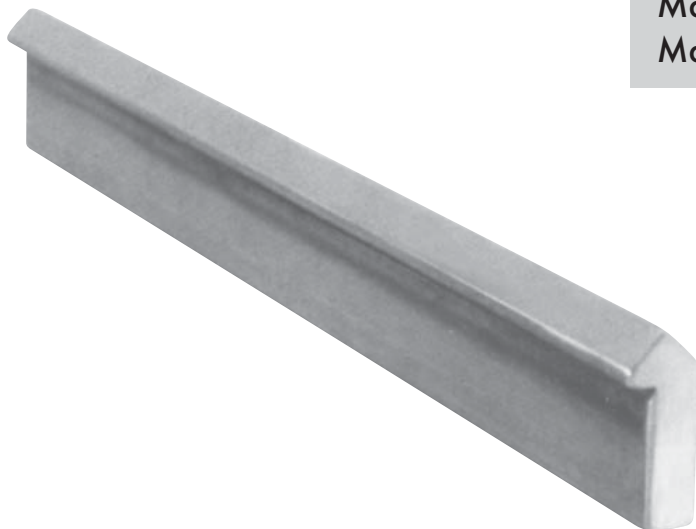

Označení	Rozměry [mm]					Hmotnost [kg/m]
	A	B	C	D	F	
VR 1	11,1	4,7	1,6	0,8	3,2	0,27
VR 2	15,9	6,4	2,4	0,8	4,7	0,51
VR 3	22,2	8,7	2,8	1,6	6,4	1,03
VR 4	27	11,1	3,2	2,4	7,9	1,64

Objednací číslo:

VR 1 1500
 | |
 | | délka kolejnice v mm
 | |
 | |
 | | typ kolejnice

Nerezové provedení na poptávku.

Výpočet zatížení

Vysvětlivky:

- L = zatížení/počet párů rolů [N]
- L_r = radiální zatížení na vodící rolnu [N]
- L_o = momentové zatížení na vodící rolnu [N]
- A = rozměr v mm
- B = rozměr v mm
- F_A = faktor použití
 - 0,5 pro použití bez rázů, s dobrým mazáním
 - 1,0 pro použití s lehkým mazáním
 - 2,0 pro použití s rázy, bez mazání nebo s nečistotami

Příklad 1

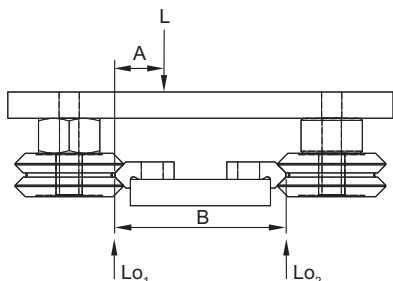

$$Lo_1 = \frac{L \cdot (B - A)}{B} \cdot F_A$$

$$Lo_2 = (L \cdot F_A) - Lo_1$$

Výpočet

Zatížení 100 N na 4 rolly, $L = 100/2$ páry rolů = 50 N
 A = 400 mm, B = 1000 mm, $F_A = 1$

$$Lo_1 = \frac{50 \cdot (1000 - 400)}{1000} \cdot 1 = 30 \text{ N}$$

$$Lo_2 = (50 \cdot 1) - 30 = 20 \text{ N}$$

Příklad 2

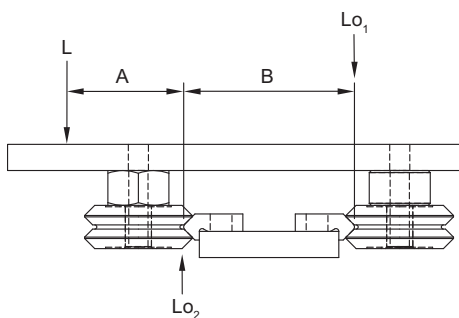

$$Lo_1 = \frac{L \cdot A}{B} \cdot F_A$$

$$Lo_2 = (L \cdot F_A) + Lo_1$$

Výpočet

Zatížení 100 N na 4 rolly, $L = 100/2$ páry rolů = 50 N
 A = 400 mm, B = 600 mm, $F_A = 1$

$$Lo_1 = \frac{50 \cdot 400}{600} \cdot 1 = 33,3 \text{ N}$$

$$Lo_2 = (50 \cdot 1) + 33,3 = 83,3 \text{ N}$$

Příklad 3

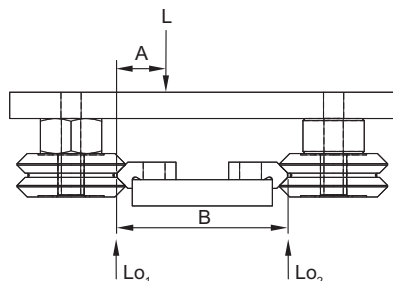

$$Lo_1 = Lo_2 = \frac{L \cdot A}{B} \cdot F_A$$

$$L_r = (L \cdot F_A) + Lo_1$$

Výpočet

Zatížení 100 N na 4 rolly, $L = 100/2$ páry rolů = 50 N
 A = 400 mm, B = 600 mm, $F_A = 1$

$$Lo_1 = \frac{50 \cdot 400}{600} \cdot 1 = 33,3 \text{ N}$$

$$L_r = (50 \cdot 1) + 33,3 = 83,3 \text{ N}$$

Montáž kolejnic

A = vzdálenost středů
 B = rozměr distanční kolejnice
 C = vzdálenost kolejnic

$$A = B + IV$$

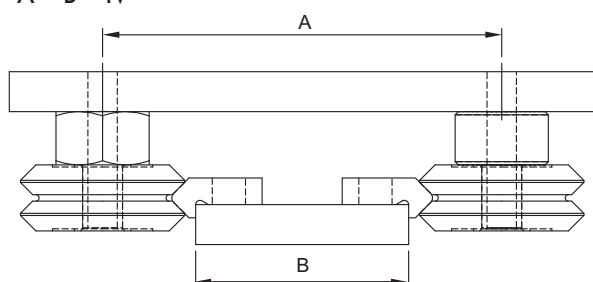

Označení kolejnice	Rozměry [mm]	
	IV	OV
VR 1	22,2	23,7
VR 2	34,9	36,5
VR 3	50,8	53,9
VR 4	60,6	69,9

$$A = C - IV$$

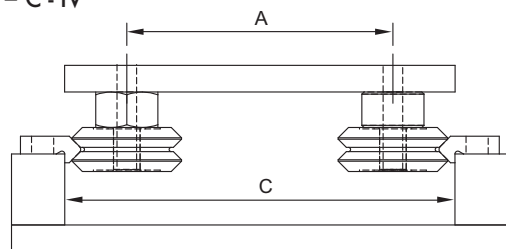

$$A = C - OV$$

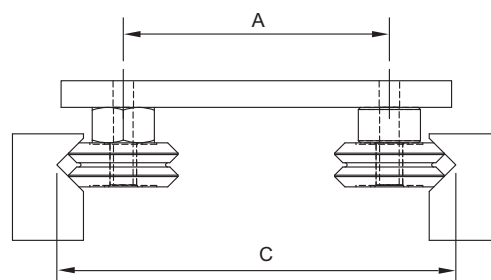

Příklad montáže rolen

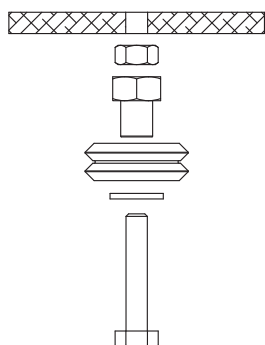

Čepy	
Označení	M
MVB 1	M4
MVB 2	M6
MVB 3	M8
MVB 4	M10

Kolejnice	
Označení	M
VR 1	M3
VR 2	M6
VR 3	M6
VR 4	M8

Rolny pro velká zatížení

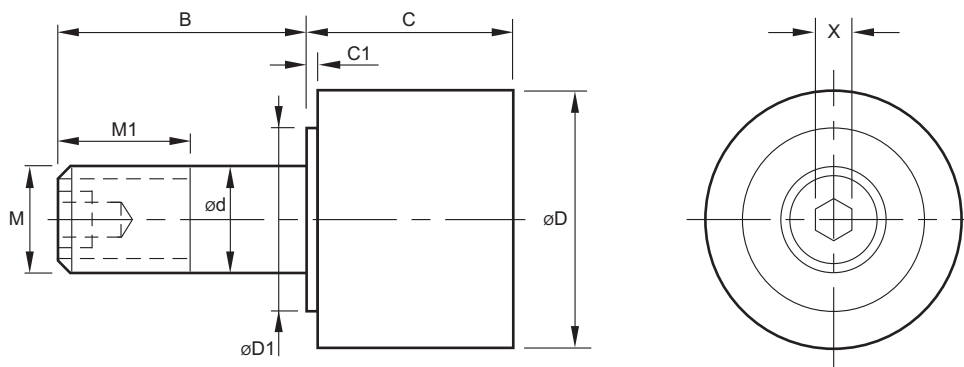
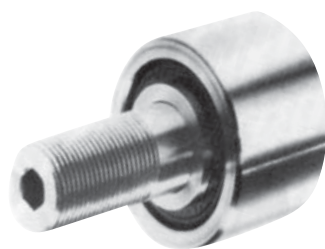

Označení	Rozměry [mm]										Hmotnost [kg]
	$\overset{+0,00}{\underset{-0,02}{\varnothing D}}$	$\overset{+0,00}{\underset{-0,02}{\varnothing d}}$	$\varnothing D1$	C	C1	B	M	M1	X	$\overset{+0,02}{\underset{-0,00}{\varnothing}}$ Vrtání pro čep rolny	
HPC 26	26	10	13,1	20,0	0,8	23,0	M10 × 1,0	13	4	10,02	0,09
HPC 30	30	12	15,9	20,0	0,8	25,0	M12 × 1,5	14	4	12,02	0,11
HPC 32	32	12	15,9	22,0	0,8	25,0	M12 × 1,5	14	4	12,02	0,14
HPC 35	35	16	19,1	22,0	0,8	32,5	M16 × 1,5	18	8	16,02	0,17
HPC 40	40	14	18,0	30,0	1,6	40,0	M14 × 2,0	26	8	14,02	0,27
HPC 40-1	40	18	22,0	27,6	1,6	36,5	M18 × 1,5	19	8	18,02	0,24
HPC 47	47	20	25,5	27,6	1,6	40,5	M20 × 1,5	21	8	20,02	0,42
HPC 50	50	16	23,0	40,0	1,6	50,0	M16 × 2,0	35	8	16,02	0,54
HPC 52	52	20	25,5	33,6	1,6	40,5	M20 × 1,5	21	8	20,02	0,54
HPC 62	62	24	32,0	44,0	1,6	58,0	M24 × 3,0	35	8	24,02	1,04
HPC 62-1	62	24	32,0	44,0	1,6	49,5	M24 × 1,5	25	8	24,02	1,04
HPC 72	72	24	32,0	44,0	1,6	49,5	M24 × 1,5	25	8	24,02	1,40
HPC 76	76	30	44,5	52,0	1,6	69,5	M30 × 3,5	40	12	30,02	1,91
HPC 80	80	30	44,5	52,0	1,6	69,5	M30 × 3,5	40	12	30,02	2,07
HPC 85	85	30	44,5	52,0	1,6	69,5	M30 × 3,5	40	12	30,02	2,37
HPC 90	90	30	44,5	52,0	1,6	69,5	M30 × 3,5	40	12	30,02	2,65
HPC 100	100	30	44,5	52,0	1,6	80,0	M30 × 3,5	50	12	30,02	3,33
HPC 100-1	100	30	44,5	52,0	1,6	69,5	M30 × 3,5	40	12	30,02	3,15
HPC 125	125	48	82,5	76,0	1,6	105,0	M48 × 5,0	60	12	48,02	8,48
HPC 150	150	64	82,5	76,0	1,6	140,0	M64 × 6,0	82	12	64,02	12,50
HPC 200	200	64	82,5	76,0	1,6	140,0	M64 × 6,0	82	12	64,02	21,87

Matky a podložky nejsou součástí dodávky.

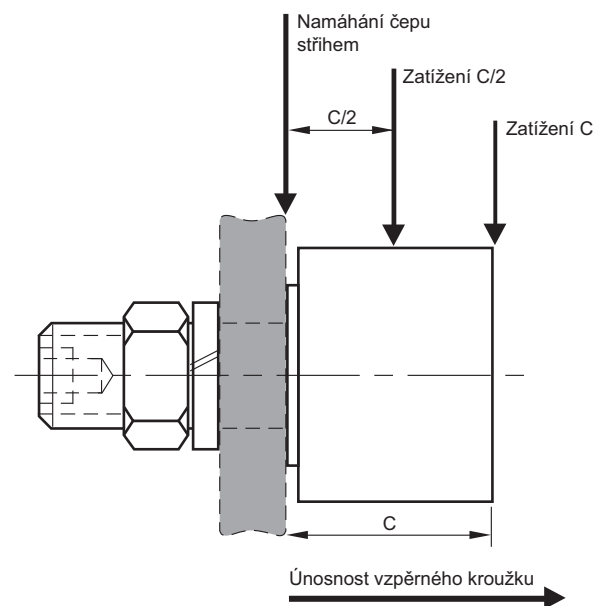

	Únosnost [N]									Únosnost vzpěrného kroužku
	Radiální zatížení rolny			Axiální zatížení rolny			Únosnost čepu			
	3000 hod. L_{10} při 100 ot./min	500 hod. L_{110} při 33 1/3 ot./min	Max. radiální zatížení, statické	3000 hod. L_{10} při 100 ot./min	500 hod. L_{110} při 33 1/3 ot./min	Max. axiální zatížení, statické	V ohybu = 0,75 S_y		Ve stříhu	
							Zatížení C/2	Zatížení C		
	1060	2790	1000	650	1720	1350	1990	900	8700	2090
	1060	2790	1000	650	1720	1350	1990	900	8700	2090
	2290	6000	2680	1410	3700	1950	3750	1670	14400	2090
	2290	6000	2680	1410	3700	1950	3750	1670	14400	2090
	4670	12200	4900	2890	7560	2650	6110	3250	25470	2090
	4670	12200	4900	2890	7560	2650	6230	3560	25470	2090
	4670	12200	4900	2890	7560	2650	6230	3560	25470	2090
	6450	17000	7200	4030	10600	3050	8790	5080	45760	4050
	6450	17000	7200	4030	10600	3050	13810	7670	50220	4050
	8800	23100	10100	5400	14200	6850	16000	8750	64850	5960
	8800	23100	10100	5400	14200	6850	16000	8750	64850	5960
	20330	48400	33900	7520	17840	20330	26860	15740	104040	
	26700	63600	89000	10800	25700	53400	44670	25880	160520	
	26700	63600	89000	10800	25700	53400	44670	25880	160520	
	26700	63600	89000	10800	25700	53400	44670	25880	160520	
	26700	63600	89000	10800	25700	53400	44670	25880	160520	
	26700	63600	89000	10800	25700	53400	44670	25880	160520	
	26700	63600	89000	10800	25700	53400	44670	25880	160520	
	62200	148100	230800	24600	58500	144600	128010	70500	411800	
	67000	159000	251000	26500	63000	147000	303430	163550	732100	
	67000	159000	251000	26500	63000	147000	303430	163550	732100	

Velikosti $\varnothing D26-62$ mají kuličkový typ ložiska, $\varnothing D72-200$ mají kuželíkový typ ložiska.

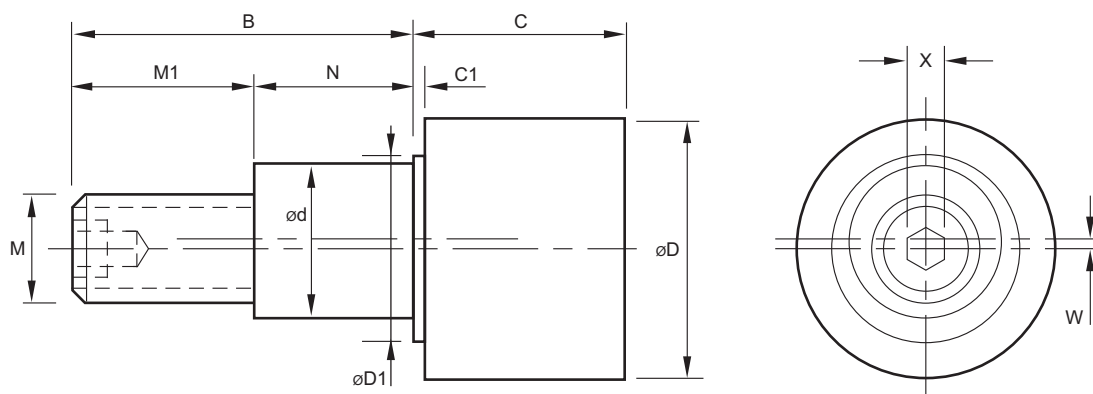

Označení	Rozměry [mm]												Hmotnost [kg]
	$\varnothing D^{+0,00}_{-0,02}$	$\varnothing d^{+0,00}_{-0,02}$	$\varnothing D1$	C	C1	B	M	M1	$N^{+0,00}_{-0,25}$	W	X	$\varnothing^{+0,02}_{-0,00}$ Vrtání pro čep rolny	
HPCE 26	26	13	17,1	20,0	0,8	23,0	M10 × 1,0	13,0	10	0,5	13	10,00	0,5
HPCE 30	30	15	17,5	20,0	0,8	25,0	M12 × 1,5	14,0	11	0,5	15	11,00	0,5
HPCE 32	32	15	17,5	22,0	0,8	25,0	M12 × 1,5	14,0	11	0,5	15	11,00	0,5
HPCE 35	35	20	23,8	22,0	0,8	32,5	M16 × 1,5	18,0	14,50	1,0	20	14,50	1,0
HPCE 40-1	40	22	28,5	27,6	1,6	36,5	M18 × 1,5	20,5	16	1,0	22	16,00	1,0
HPCE 47	47	24	32,0	27,6	1,6	40,5	M20 × 1,5	22,5	18	1,0	24	18,00	1,0
HPCE 50	50	24	32,0	40,0	1,6	50,0	M16 × 2,0	32,0	18	1,0	24	18,00	1,0
HPCE 52	52	24	32,0	33,6	1,6	40,5	M20 × 1,5	22,5	18	1,0	24	18,00	1,0
HPCE 62	62	28	43,0	44,0	1,6	58,0	M24 × 3,0	38,0	20	1,5	28	20,00	1,5
HPCE 62-1	62	28	43,0	44,0	1,6	49,5	M24 × 1,5	27,5	22	1,0	28	22,00	1,0
HPCE 72	72	28	38,0	44,0	1,6	49,5	M20 × 1,5	27,5	22	1,0	28	22,00	1,0
HPCE 76-1	76	35	50,0	52,0	1,6	70,0	M24 × 1,5	41,0	29	1,5	35	29,00	1,5
HPCE 80	80	35	50,0	52,0	1,6	70,0	M24 × 1,5	41,0	29	1,5	35	29,00	1,5
HPCE 85	85	35	50,0	52,0	1,6	70,0	M24 × 1,5	41,0	29	1,5	35	29,00	1,5
HPCE 90	90	35	50,0	52,0	1,6	70,0	M24 × 1,5	41,0	29	1,5	35	29,00	1,5
HPCE 100	100	35	50,0	52,0	1,6	70,0	M24 × 1,5	41,0	29	1,5	35	29,00	1,5
HPCE 125	125	64	82,5	76,0	1,6	105,0	M48 × 5,0	55,0	50	1,5	64	50,00	1,5
HPCE 150	150	80	82,5	76,0	1,6	140,0	M64 × 6,0	75,0	65	1,5	80	65,00	1,5

Matky a podložky nejsou součástí dodávky.

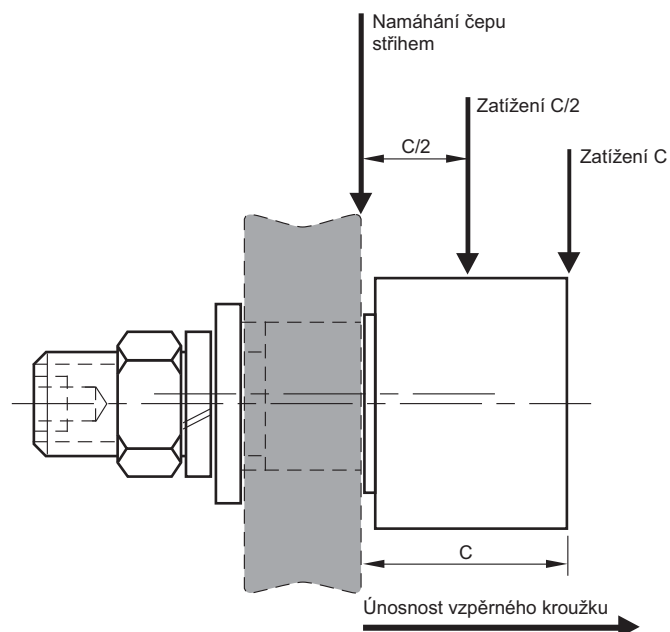

	Únosnost [N]									
	Radiální zatížení rolny			Axiální zatížení rolny			Únosnost čepu			Únosnost vzpěrného kroužku
	3000 hod. L_{10} při 100 ot./min	500 hod. L_{10} při 33 1/3 ot./min	Max. radiální zatížení, statické	3000 hod. L_{10} při 100 ot./min	500 hod. L_{10} při 33 1/3 ot./min	Max. axiální zatížení, statické	V ohybu = 0,75 S_y		Ve střihu	
							Zatížení C/2	Zatížení C		
1060	2790	1000	650	1720	1350	1990	900	8700	2090	
1060	2790	1000	650	1720	1350	1990	900	8700	2090	
2290	6000	2680	1410	3700	1950	3750	1670	14400	2090	
2290	6000	2680	1410	3700	1950	3750	1670	14400	2090	
4670	12200	4900	2890	7560	2650	6230	3250	25470	2090	
4670	12200	4900	2890	7560	2650	6230	3250	25470	2090	
6450	17700	7200	4030	10600	3050	14450	7740	51750	4050	
6450	17700	7200	4030	10600	3050	14450	7740	51750	4050	
8800	23100	10100	5400	14200	6850	16000	8680	64850	5960	
8800	23100	10100	5400	14200	6850	16000	8680	64850	5960	
20330	48400	33950	7520	17840	20330	17990	9870	71950		
26700	63600	89000	10800	25700	53400	27840	14690	101870		
26700	63600	89000	10800	25700	53400	27840	14690	101870		
26700	63600	89000	10800	25700	53400	27840	14690	101870		
26700	63600	89000	10800	25700	53400	27840	14690	101870		
26700	63600	89000	10800	25700	53400	27840	14690	101870		
62200	148100	230800	24600	58500	144600	143070	74830	411800		
67000	159000	251000	26500	63100	147000	330120	173200	720500		

Velikosti $\varnothing D26-62$ mají kuličkový typ ložiska, $\varnothing D72-150$ mají kuželíkový typ ložiska.

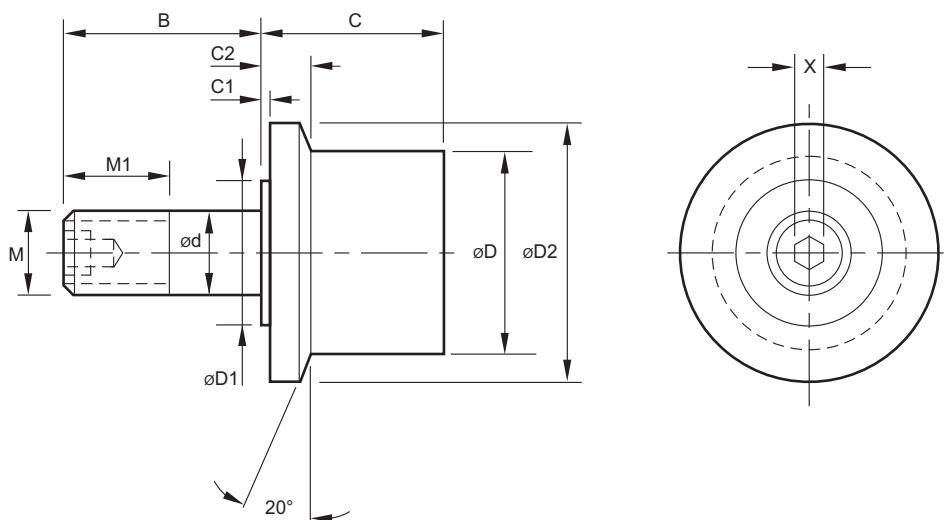

Označení	Rozměry [mm]											Hmot. [kg]	
	$\varnothing D$	$\varnothing d$	$\varnothing D1$	$\varnothing D2$	C	C1	C2	B	M	M1	X		$^{+0,02}_{-0,00}$ Vrtání pro čep rolny
HPJ 26	26	10	13,1	35	20,0	0,8	5,0	23,0	M10 × 1,0	13	4	10,02	0,11
HPJ 30	30	12	15,9	40	20,0	0,8	5,0	25,0	M12 × 1,5	14	4	12,02	0,14
HPJ 32	32	12	15,9	42	22,0	0,8	5,0	25,0	M12 × 1,5	14	4	12,02	0,17
HPJ 35	35	16	19,1	46	22,0	0,8	5,0	32,5	M16 × 1,5	18	8	16,02	0,20
HPJ 40	40	14	18,0	54	30,0	1,6	8,8	40,0	M14 × 2,0	26	8	14,02	0,33
HPJ 40-1	40	18	22,0	54	27,6	1,6	7,8	36,5	M18 × 1,5	19	8	18,02	0,24
HPJ 47	47	20	25,5	61	27,6	1,6	7,8	40,5	M20 × 1,5	21	8	20,02	0,47
HPJ 50	50	16	23,0	68	40,0	1,6	14,0	50,0	M16 × 2,0	35	8	16,02	0,70
HPJ 52	52	20	25,5	66	33,6	1,6	10,8	40,5	M20 × 1,5	21	8	20,02	0,83
HPJ 62	62	24	32,0	78	44,0	1,6	14,0	58,0	M24 × 3,0	35	8	24,02	1,21
HPJ 62-2	62	24	32,0	78	44,0	1,6	14,0	49,5	M24 × 1,5	25	8	24,02	1,21
HPJ 72	72	24	32,0	90	44,0	1,6	14,0	49,5	M24 × 1,5	25	8	24,02	1,28
HPJ 76	76	30	44,5	98	52,0	1,6	14,0	69,5	M30 × 3,5	40	12	30,02	2,17
HPJ 80	80	30	44,5	102	52,0	1,6	14,0	69,5	M30 × 3,5	40	12	30,02	2,41
HPJ 85	85	30	44,5	107	52,0	1,6	14,0	69,5	M30 × 3,5	40	12	30,02	2,75
HPJ 90	90	30	44,5	112	52,0	1,6	14,0	69,5	M30 × 3,5	40	12	30,02	2,98
HPJ 100	100	30	44,5	125	52,0	1,6	14,0	80,0	M30 × 3,5	50	12	30,02	3,70
HPJ 100-1	100	30	44,5	125	52,0	1,6	14,0	69,5	M30 × 3,5	40	12	30,02	3,52
HPJ 125	125	48	82,5	148	76,0	1,6	18,0	105,0	M48 × 5,0	60	12	48,02	8,86
HPJ 150	150	64	82,5	173	76	1,6	18,3	140,0	M64 × 6,0	82	12	64,02	13,07
HPJ 200	200	64	82,5	223	76	1,6	18,3	140,0	M64 × 6,0	82	12	64,02	20,37

Matky a podložky nejsou součástí dodávky.

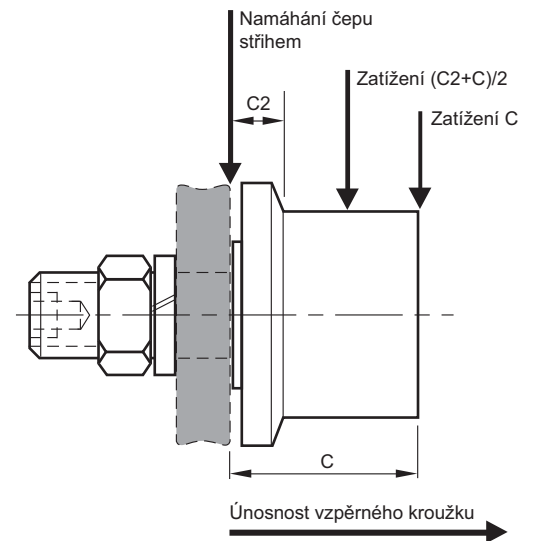

Únosnost [N]										
Radiální zatížení rolny			Axiální zatížení rolny			Únosnost čepu			Únosnost vzpěrného kroužku [N]	
3000 hod. L ₁₀ při 100 ot./min	500 hod. L ₁₀ při 33 1/3 ot./min	Max. radiální zatížení, statické	3000 hod. L ₁₀ při 100 ot./min	500 hod. L ₁₀ při 33 1/3 ot./min	Max. axiální zatížení, statické	V ohybu = 0,75 S _y		Ve stříhu		
						Zatížení (C2+C)/2	Zatížení C			
1060	2790	1000	650	1720	1350	1560	900	8700	2090	
1060	2790	1000	650	1720	1350	1560	900	8700	2090	
2290	6000	2680	1410	3700	1950	2950	1670	14400	2090	
2290	6000	2680	1410	3700	1950	2950	1670	14400	2090	
4670	12200	4900	2890	7560	2650	5000	3320	25470	2090	
4670	12200	4900	2890	7560	2650	5000	3320	25470	2090	
4670	12200	4900	2890	7560	2650	5000	3320	25470	2090	
6450	17000	7200	4030	10600	3050	6860	5000	45760	4050	
6450	17000	7200	4030	10600	3050	11110	7810	51750	4050	
8800	23100	10100	5400	14200	6850	12280	8740	64850	5960	
8800	23100	10100	5400	14200	6850	12280	8740	64850	5960	
20330	48400	33950	7520	17840	20330	20820	15250	101860		
26700	63600	89000	10800	25700	53400	37000	25880	160520		
26700	63600	89000	10800	25700	53400	37000	25880	160520		
26700	63600	89000	10800	25700	53400	37000	25880	160520		
26700	63600	89000	10800	25700	53400	37000	25880	160520		
26700	63600	89000	10800	25700	53400	37000	25880	160520		
26700	63600	89000	10800	25700	53400	37000	25880	160520		
26700	63600	89000	10800	25700	53400	37000	25880	160520		
62200	148100	230800	24600	58500	144600	105750	69000	411800		
67000	159000	251000	26500	63000	147000	247430	160830	720500		
67000	159000	251000	26500	63000	147000	247430	160830	720500		

Velikosti ØD26-62 mají kuličkový typ ložiska, ØD72-200 mají kuželíkový typ ložiska.

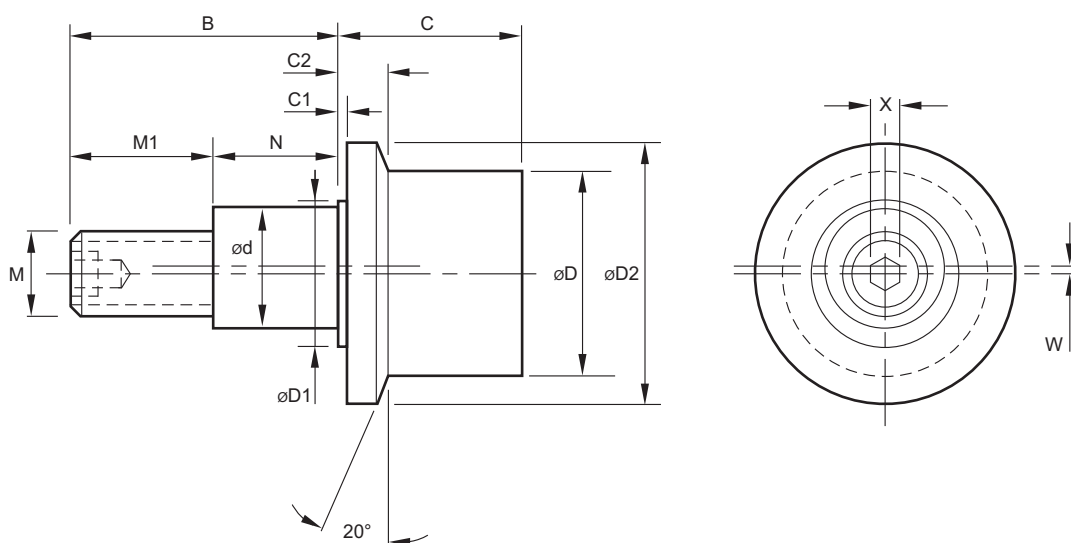
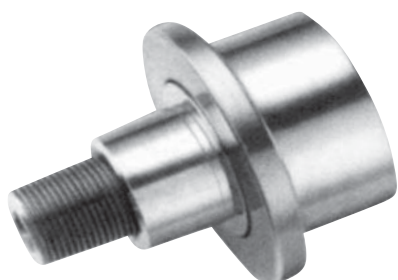

Označení	Rozměry [mm]														Hmot. [kg]
	$\varnothing D$	$\varnothing d^{+0,00/-0,05}$	$\varnothing D1$	$\varnothing D2$	C	$C1$	$C2$	B	M	$M1$	$N^{+0,00/-0,25}$	W	X	\varnothing Vrtání pro čep rolny	
HPJE 26	26	13	17,1	35	20,0	0,8	5,0	23,0	M10 × 1,0	13,0	10,00	0,5	4	13,02	0,14
HPJE 30	30	15	17,5	40	20,0	0,8	5,0	25,0	M12 × 1,5	14,0	11,00	0,5	4	15,02	0,17
HPJE 32	32	15	17,5	42	22,0	0,8	5,0	25,0	M12 × 1,5	14,0	11,00	0,5	4	15,02	0,20
HPJE 35	35	20	23,8	46	22,0	0,8	5,0	32,5	M16 × 1,5	18,0	14,50	1,0	8	20,02	0,23
HPJE 40-1	40	22	28,5	54	27,6	1,6	7,8	36,5	M18 × 1,5	20,5	16,00	1,0	8	22,02	0,35
HPJE 50	50	24	32,0	68	40,0	1,6	14,0	50,0	M16 × 2,0	32,0	18,00	1,0	8	24,02	0,94
HPJE 62-1	62	28	43,0	78	44,0	1,6	14,0	49,5	M24 × 1,5	27,5	22,00	1,0	8	28,02	1,13
HPJE 76	76	35	50,0	98	52,0	1,6	14,0	70,0	M24 × 1,5	41,0	29,00	1,5	8	35,02	2,31
HPJE 90	90	35	50,0	112	52,0	1,6	14,0	70,0	M24 × 1,5	41,0	29,00	1,5	8	35,02	3,09
HPJE 100	100	35	50,0	125	52,0	1,6	14,0	70,0	M24 × 1,5	41,0	29,00	1,5	8	35,02	3,79
HPJE 125	125	64	82,5	148	76,0	1,6	18,0	105,0	M48 × 5,0	55,0	50,00	1,5	12	64,02	9,28
HPJE 150	150	80	92,0	173	76,0	1,6	18,3	140,0	M64 × 6,0	75,0	65,00	1,5	12	80,02	14,86

Matky a podložky nejsou součástí dodávky.

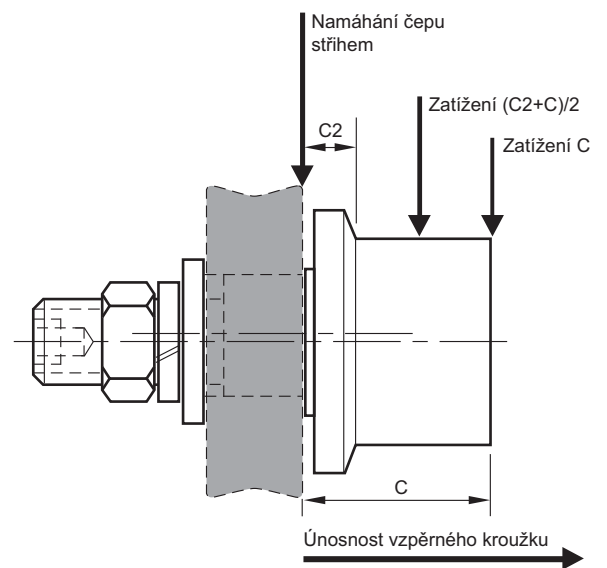

Únosnost [N]									
Radiální zatížení rolny			Axiální zatížení rolny			Únosnost čepu			Únosnost vzpěrného kroužku [N]
3000 hod. L ₁₀ při 100 ot./min	500 hod. L ₁₀ při 33 1/3 ot./min	Max. radiální zatížení, statické	3000 hod. L ₁₀ při 100 ot./min	500 hod. L ₁₀ při 33 1/3 ot./min	Max. axiální zatížení, statické	V ohybu = 0,75 S _y		Ve střihu	
						Zatížení (C2+C)/2	Zatížení C		
1060	2790	1000	650	1720	1350	1560	900	8700	2090
1060	2790	1000	650	1720	1350	1560	900	8700	2090
2290	6000	2680	1410	3700	1950	2950	1670	14400	2090
2290	6000	2680	1410	3700	1950	2950	1670	14400	2090
4670	12200	4900	2890	7560	2650	4990	3560	25470	2090
6450	17000	7200	4030	10600	3050	12040	7740	51750	4050
8800	23100	10100	5400	14200	6850	12160	8750	64850	5960
26700	63600	89000	10800	25700	53400	22670	15160	104040	
26700	63600	89000	10800	25700	53400	22670	15160	104040	
26700	63600	89000	10800	25700	53400	22670	15160	104040	
62200	148100	230800	24600	58500	144600	117220	75420	411800	
67000	159000	251000	26500	63000	147000	270280	171880	720520	

Velikosti \varnothing D26-62 mají kuličkový typ ložiska, \varnothing D72-150 mají kuželíkový typ ložiska.

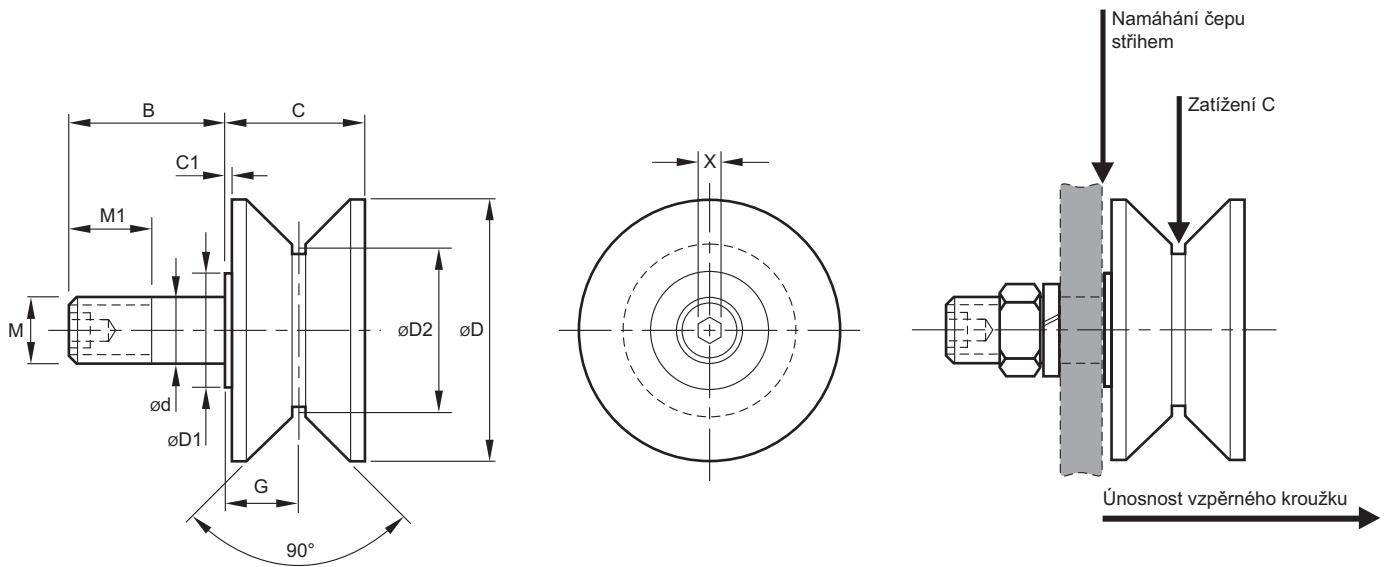

Označení	Rozměry [mm]												Hmot. [kg]
	øD	ød ^{+0,00} _{-0,02}	øD1	øD2	C	C1	G	B	M	M1	X	Vrtání pro čep rolny ^{+0,02} _{-0,00}	
HPV 26	40	10	13,1	26	20,0	0,8	10,0	23,0	M10 × 1,0	13,0	4	10,02	0,23
HPV 32	50	12	15,9	32	22,0	0,8	11,0	25,0	M12 × 1,5	14,0	4	12,02	0,26
HPV 40	60	14	18,0	40	33,0	1,6	17,0	40,0	M14 × 2,0	26,0	8	14,02	0,44
HPV 62	90	24	32,0	62	44,5	1,6	23,0	57,9	M24 × 3,0	34,9	8	24,02	1,48
HPV 62-1	90	24	32,0	62	44,5	1,6	23,0	49,5	M24 × 1,5	25,0	8	24,02	1,45
HPV 76	120	30	44,5	76	50,5	1,6	26,0	70,0	M30 × 3,5	40,0	12	30,02	2,69
HPV 100	140	30	44,5	100	50,5	1,6	26,0	80,0	M30 × 3,5	50,0	12	30,02	4,11
HPV 100-1	140	30	44,5	100	50,5	1,6	26,0	69,5	M30 × 3,5	40,0	12	30,02	4,05
HPV 125	165	48	82,5	125	76,0	1,6	37,8	105,0	M48 × 5,0	60,0	12	48,02	9,92

Označení	Únosnost [N]								
	Radiální zatížení rolny			Axiální zatížení rolny			Únosnost čepu		Únosnost vzpěrného kroužku [N]
	3000 hod. L ₁₀ při 100 ot./min	500 hod. L ₁₀ při 33 1/3 ot./min	Max. radiální zatížení, statické	3000 hod. L ₁₀ při 100 ot./min	500 hod. L ₁₀ při 33 1/3 ot./min	Max. axiální zatížení, statické	V ohybu = 0,75 Sy Zatížení C	Ve stříhu	
HPV 26	1060	2790	1000	650	1720	1350	2020	8700	2090
HPV 32	2290	6000	2680	1410	3700	1950	3950	14400	2090
HPV 40	4670	12200	4900	2890	7560	2650	7030	34870	2090
HPV 62	8800	23100	10100	5400	14200	6850	17130	64850	5960
HPV 62-1	8800	23100	10100	5400	14200	6850	17130	64850	5960
HPV 76	26700	63500	89000	10800	25700	53400	45930	160520	
HPV 100	26700	63500	89000	10800	25700	53400	45930	160520	
HPV 100-1	26700	63500	89000	10800	25700	53400	45930	160520	
HPV 125	62200	148100	168800	24600	58500	144600	130590	291230	

Matky a podložky nejsou součástí dodávky.

Velikosti øD26-62 mají kuličkový typ ložiska, øD72-125 mají kuželíkový typ ložiska.

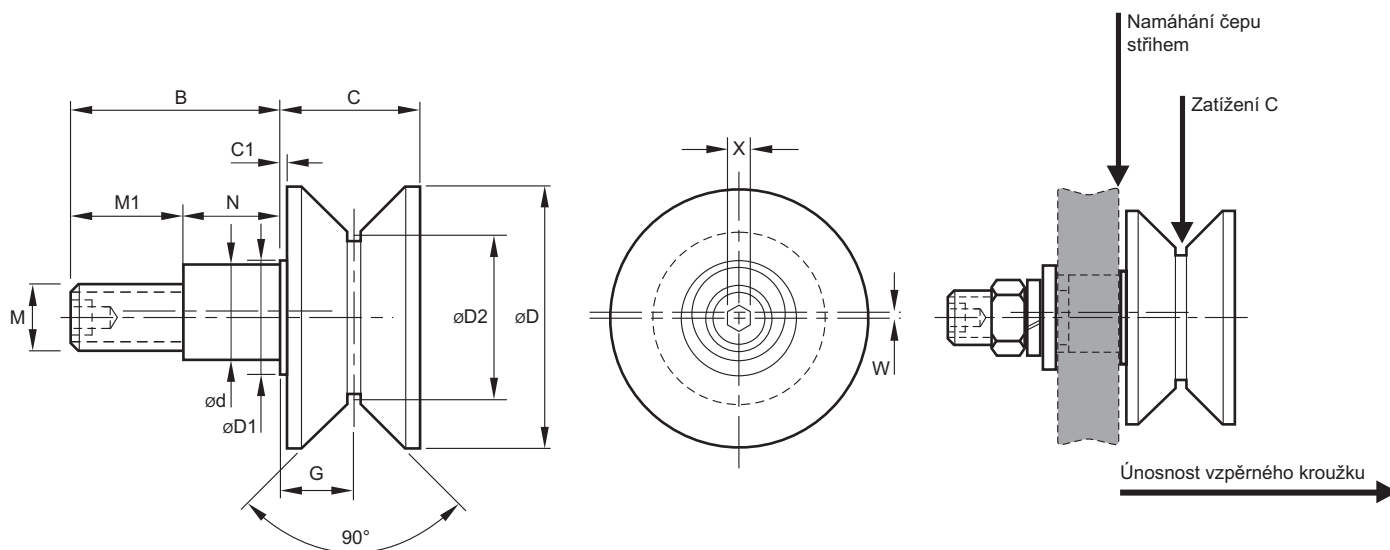

Označení	Rozměry [mm]													Hmot. [kg]
	øD	ød ^{+0,00} _{-0,02}	øD1	øD2	C	C1	G	M	M1	N	W	X	Vrtání pro čep rolny ^{+0,02} _{ø0,00}	
HPVE 26	40	13,00	17,1	26	20,0	0,8	10,0	M10 × 1,0	23,0	10,00	0,5	4	13,02	0,26
HPVE 32	50	15,00	17,5	32	22,0	0,8	11,0	M12 × 1,5	25,0	11,00	0,5	4	15,02	0,30
HPVE 40	60	22,00	28,5	40	33,0	1,6	17,0	M14 × 2,0	40,0	16,00	1,0	8	22,02	0,48
HPVE 62	90	28,00	43,0	62	44,5	1,6	23,0	M24 × 3,0	58,0	20,00	1,5	8	28,02	1,51
HPVE 62-1	90	28,00	43,0	62	44,5	1,6	23,0	M24 × 1,5	49,5	22,00	1,0	8	28,02	1,48
HPVE 76	120	35,00	50,0	76	50,5	1,6	26,0	M24 × 1,5	70,0	29,00	1,5	8	35,02	2,67
HPVE 100	140	35,00	50,0	100	50,5	1,6	26,0	M24 × 1,5	70,0	29,00	1,5	8	35,02	4,04
HPVE 125	165	64,00	82,5	125	76,0	1,6	37,8	M48 × 5,0	105,0	50,00	1,5	12	64,02	10,47

Označení	Únosnost [N]								
	Radiální zatížení rolny			Axiální zatížení rolny			Únosnost čepu		Únosnost vzpěrného kroužku [N]
	3000 hod. L ₁₀ při 100 ot./min	500 hod. L ₁₀ při 33 1/3 ot./min	Max. radiální zatížení, statické	3000 hod. L ₁₀ při 100 ot./min	500 hod. L ₁₀ při 33 1/3 ot./min	Max. axiální zatížení, statické	V ohybu = 0,75 Sy Zatížení C	Ve stříhu	
HPVE 26	1060	2790	1000	650	1720	1350	2020	8700	2090
HPVE 32	2290	6000	2680	1410	3700	1950	3950	14400	2090
HPVE 40	4670	12200	4900	2890	7560	2650	5440	25470	2090
HPVE 62	8800	23100	10100	5400	14200	6850	15790	64850	5960
HPVE 62-1	8800	23100	10100	5400	14200	6850	15790	64850	5960
HPVE 76	26700	63500	89000	10800	25700	53400	28840	101860	
HPVE 100	26700	63500	89000	10800	25700	53400	28840	101860	
HPVE 125	62200	148100	168800	24600	58500	144600	147400	291230	

Matky a podložky nejsou součástí dodávky.

Velikosti øD26-62 mají kuličkový typ ložiska, øD72-125 mají kuželíkový typ ložiska.

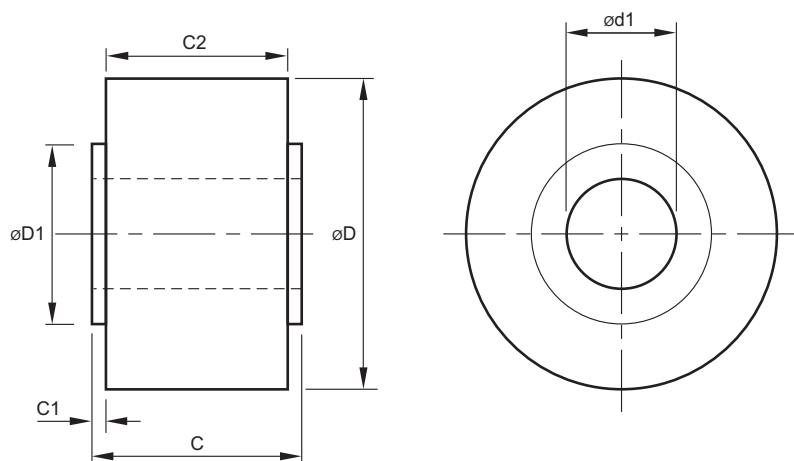
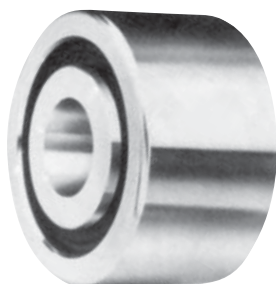

Označení	Rozměry [mm]						Únosnost [N]						Hmotnost [kg]
	øD	ød1	øD1	C	C1	C2	Radiální zatížení rolny			Axiální zatížení rolny			
							3000 hod. L ₁₀ při 100 ot./min	500 hod. L ₁₀ při 33 1/3 ot./min	Max. radiální zatížení, statické	3000 hod. L ₁₀ při 100 ot./min	500 hod. L ₁₀ při 33 1/3 ot./min	Max. axiální zatížení, statické	
HPCA 62	62	20	32,0	40	1,0	38	20300	48400	33900	7500	17800	20300	0,81
HPCA 76	76	25	44,5	46	1,0	44	26700	63500	89000	10800	25700	53400	1,40
HPCA 80	80	25	44,5	46	1,0	44	26700	63500	89000	10800	25700	53400	1,57
HPCA 85	85	25	44,5	46	1,0	44	26700	63500	89000	10800	25700	53400	1,79
HPCA 90	90	30	57,2	56	1,0	54	32900	78200	121000	10700	25600	58300	2,40
HPCA 100	100	30	57,2	56	1,0	54	32900	78200	121000	10700	25600	58300	3,03
HPCA 125	125	45	82,6	71	1,5	68	62200	148100	230800	24600	58500	144600	5,70
HPCA 150	150	55	88,9	73	1,5	70	67000	159000	251000	26500	63000	147000	8,40
HPCA 200	200	70	108,0	79	1,5	76	79200	188600	355000	32400	77400	215000	16,45
HPCA 250	250	70	108,0	79	1,5	76	79200	188600	355000	32400	77400	215000	26,99

Všechny velikosti mají kuželkový typ ložiska.
Odpovídající upínací čepy - viz str. 39.

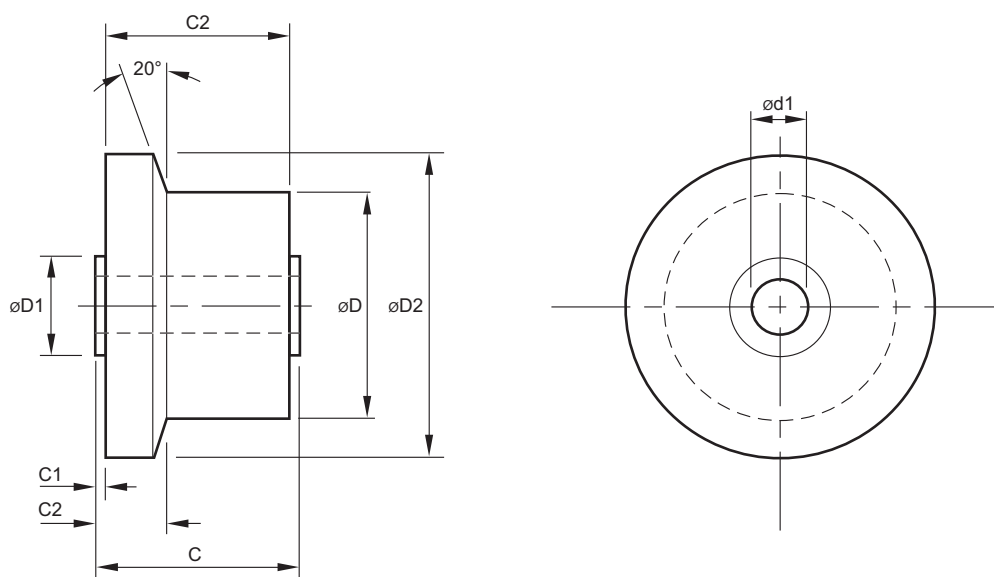

Označení	Rozměry [mm]								Únosnost [N]						Hmot. [kg]
	øD	ød1	øD1	øD2	C	C1	C2	C3	Radiální zatížení rolny			Axiální zatížení rolny			
									3000 hod. L ₁₀ při 100 ot./min	500 hod. L ₁₀ při 33 1/3 ot./min	Max. radiální zatížení, statické	3000 hod. L ₁₀ při 100 ot./min	500 hod. L ₁₀ při 33 1/3 ot./min	Max. axiální zatížení, statické	
HPJA 62	62	20	32,0	78	40	1,0	14,0	38	20300	48400	33900	7500	17800	20300	0,97
HPJA 76	76	25	44,5	98	46	1,0	13,5	44	26700	63500	89000	10800	25700	53400	1,65
HPJA 80	80	25	44,5	102	46	1,0	13,5	44	26700	63500	89000	10800	25700	53400	1,82
HPJA 85	85	25	44,5	107	46	1,0	13,5	44	26700	63500	89000	10800	25700	53400	2,06
HPJA 90	90	30	57,2	112	56	1,0	13,5	54	32900	78200	121000	10700	25600	58300	2,69
HPJA 100	100	30	57,2	122	56	1,0	13,5	54	32900	78200	121000	10700	25600	58300	3,35
HPJA 125	125	45	82,6	148	71	1,5	18,2	68	62200	148100	230800	24600	58500	144600	6,27
HPJA 150	150	55	88,9	173	73	1,5	18,2	70	67000	159000	251000	26500	63000	147000	9,07
HPJA 200	200	70	108,0	223	79	1,5	18,2	76	79200	188600	355000	32400	77400	215000	17,33
HPJA 250	250	70	108,0	273	79	1,5	18,2	76	79200	188600	355000	32400	77400	215000	28,07

Všechny velikosti mají kuželkový typ ložiska.
Odpovídající upínací čepy - viz str. 39.

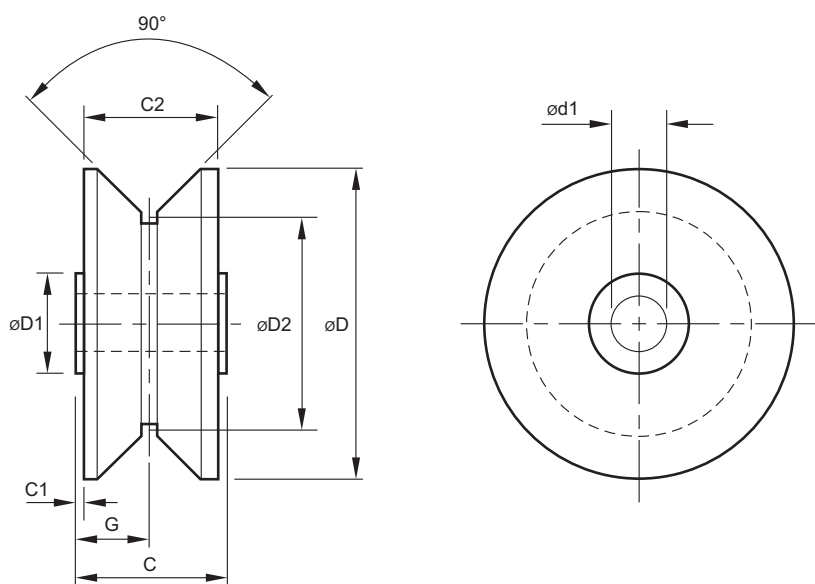
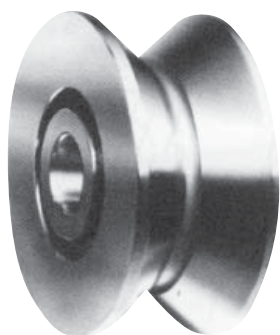

Označení	Rozměry [mm]								Únosnost [N]						Hmot. [kg]
	øD	ød1	øD1	øD2	C	C1	C2	G	Radiální zatížení rolny			Axiální zatížení rolny			
									3000 hod. L ₁₀ při 100 ot./min	500 hod. L ₁₀ při 33 1/3 ot./min	Max. radiální zatížení, statické	3000 hod. L ₁₀ při 100 ot./min	500 hod. L ₁₀ při 33 1/3 ot./min	Max. axiální zatížení, statické	
HPVA62	90	20	32,0	62	40	1,0	38	22,0	20300	48400	33900	7500	17800	20300	1,02
HPVA76	110	25	44,5	76	46	1,0	44	23,0	26700	63600	89000	10800	25700	53400	1,77
HPVA100	140	30	57,2	100	56	1,0	54	28,0	32900	78200	121000	10700	25600	58300	3,73
HPVA125	165	45	82,6	125	71	1,5	68	35,5	62200	148100	168880	24600	58500	97500	6,79
HPVA150	190	55	88,9	150	73	1,5	70	36,5	67000	159200	198400	26500	63000	99200	9,74
HPVA200	240	70	108,0	200	79	1,5	76	39,5	79200	188600	268200	32400	77400	133900	18,37
HPVA250	290	70	108,0	250	79	1,5	76	39,5	79200	188600	268200	32400	77400	133900	29,38

Všechny velikosti mají kuželíkový typ ložiska.
Odpovídající upínací čepy - viz str. 39.

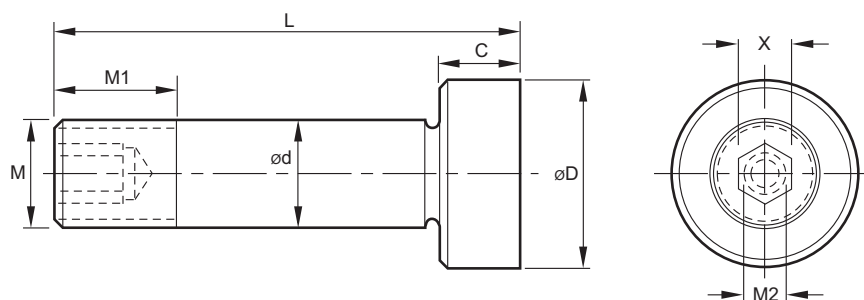

Označení	Rozměry [mm]								Čep pro rolny			Hmot. [kg]
	ød	øD	C	L	M	M1	M2	X	HPCA	HPJA	HPVA	
MSHA 20	20	31,75	16	94	M20 × 1,5	25	M6 × 1	8	62	62	62	0,70
MSHA 25	25	44,50	19	110	M24 × 1,5	29	M6 × 1	8	76	76	76	0,75
									80	80		
									85	85		
MSHA 30	30	57,20	22	135	M30 × 3,5	31	M8 × 1,25	12	90	90	100	0,95
									100	100		
MSHA 45	45	82,60	32	185	M45 × 4,5	54	M12 × 1,75	12	125	125	125	1,50
MSHA 55	55	88,90	32	195	M52 × 5	62	M12 × 1,75	12	150	150	150	5,70
MSHA 70	70	108,00	35	220	M70 × 6	74	M12 × 1,75	12	200	200	200	10,00
									250	250	250	

Matky a podložky nejsou součástí dodávky.

Kolejnice pro rolny pro vysoká zatížení

Vodící kolejnice jsou vyrobeny z kvalitní ušlechtilé oceli, vyrábějí se jako prismačké typ MTV a MPV nebo ploché typ MTP. Maximální zatížení kolejnice je 317450 N na rolnu. Kolejnice mají dva stupně tvrdosti:

- typ L má tvrdost 55-60 HRC,
- typ H s tvrdostí 38 HRC.

Vodící kolejnice lze také dodat v nerezovém provedení.

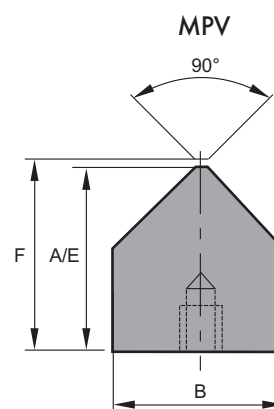
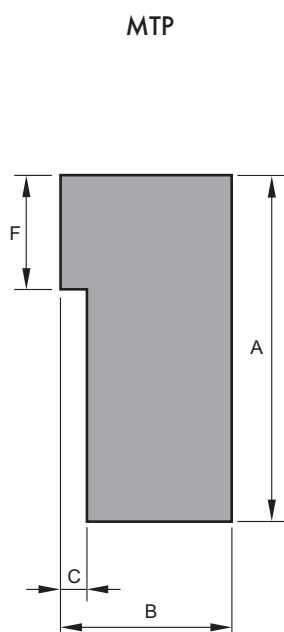
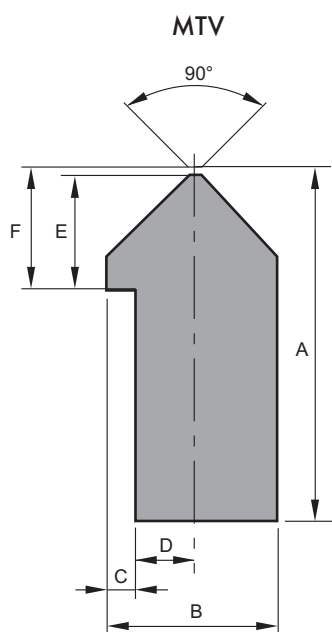

Označení	Rozměry [mm]							Montáž		
	A	B	C	D	E	F	G	1	2	3
L/H-MTV-1	75	40	6	14	27	25,8	20			
L/H-MTV-2	100	50	6	19	39	37,2	25			
L/H-MTP-1	75	40	6		27		20			
L/H-MTP-2	100	50	6		39		25			
L/H-MPV-1	38,2	40				40				
L/H-MPV-2	48,2	50				50				

Objednáací číslo:

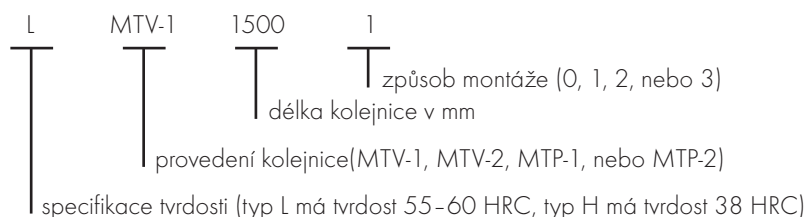

Kombinované rolny a profily

Pojezdové rolny

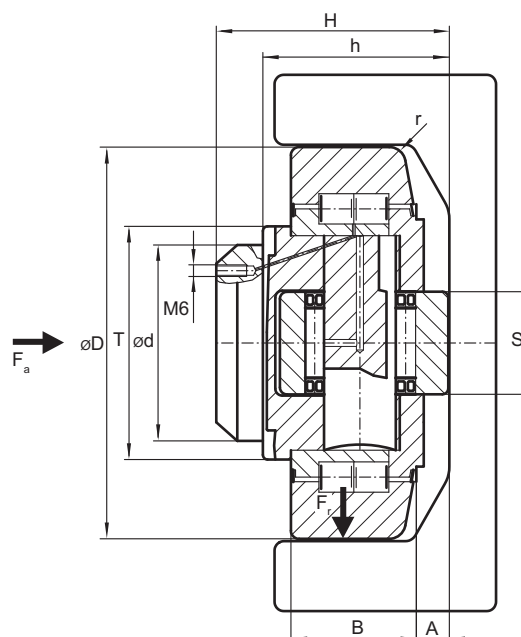

Označení	Rozměry [mm]									Únosnost [kN]						Hmot. [kg]
	øD	ød ^{0,05}	T	h	H	A	B	S	r	Stat. zatížení		Dynam. zatížení		F _a	F _r	
										C _a	C _r	C _a	C _r			
HVB 4.053*	52,5	30	40	27,0	33,0	5,0	17	15	2	7	32	7	24	1,68	5,23	0,46
HVB 4.054*	62,0	30	42	30,5	37,5	2,5	20	20	3	11	35,5	11	31	3,10	9,40	0,53
HVB 4.055	70,1	35	48	36,0	44,0	2,5	23	22	4	14	51	13	45,5	3,73	11,30	0,80
HVB 4.056	77,7	40	54	36,5	48,0	3,0	23	24	4	18	56,8	18	48	3,87	11,72	1,00
HVB 4.057	78,1	40	54	29,0	40,7	3,0	23	24	4	18	56,8	18	48	3,87	11,72	0,87
HVB 4.058	88,4	45	59	44,0	57,0	3,5	30	26	4	23	72	23	68	6,76	20,47	1,62
HVB 4.059	101,8	50	67	33,0	46,0	3,0	28	30	3	27	82	25	73	6,70	20,11	1,74
HVB 4.060	107,7	55	71	40,0	54,0	3,0	31	34	5	36	95	31	81	7,16	21,68	2,27
HVB 4.061	107,7	60	71	55,0	69,0	4,0	31	34	5	36	95	31	81	7,16	21,68	2,82
HVB 4.062	123,0	60	80	56,0	72,3	5,0	37	40	5	50	132	43	110	10,20	30,92	3,89
HVB 4.063	149,0	60	108	58,5	78,5	5,5	45	50	3	71	190	68	151	17,80	54,02	6,52

*Bez možnosti domazávání.

Nerezová provedení, s excentrem, nebo s axiálním ložiskem na poptávku.

Upínací desky pro kombinované rolny

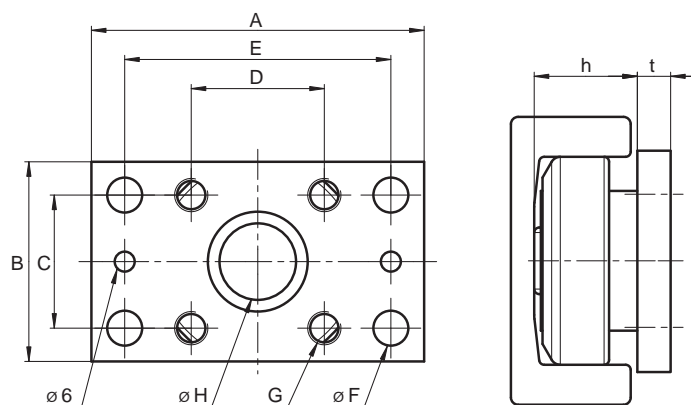

Označení	Rozměry [mm]									Rolny
	A	B	C	D	E	$\varnothing F$	G	$\varnothing H$	t	
HVPS 1	90	50	30	40	70	8,5	M8	30	10	HVB 4.053
HVP0 1	100	60	40	40	80	10,5	M10	30	10	HVB 4.054
HVP1 1	120	80	50	50	90	12,5	M12	35	15	HVB 4.055
HVP2 1	120	80	50	50	90	12,5	M12	40	15	HVB 4.056
HVP3 1	160	100	60	60	120	17,0	M16	45	20	HVB 4.058
HVP4 1	180	120	80	80	140	17,0	M16	60	20	HVB 4.061/62
HVP6 1	200	150	100	100	160	17,0	M16	60	20	HVB 4.063

Kolejnice

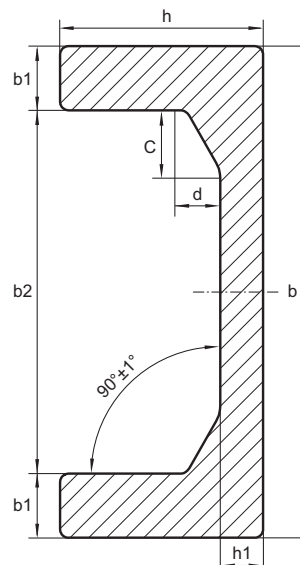
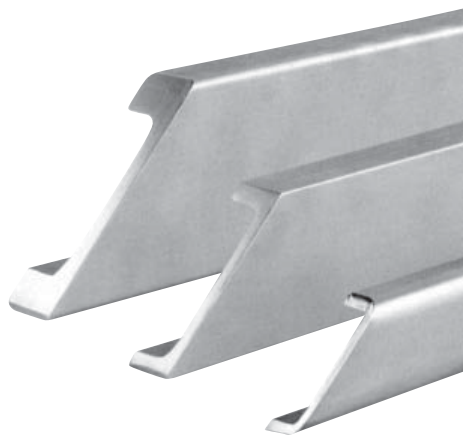

Označení	Rozměry [mm]						Rolny	W_x [cm ³]	Hmotnost [kg/m]
	b	h	h1	b1	b2	c			
HVR S	65,0	30 ^{±0,5}	6,0 ^{±0,5}	6,0 ^{±0,5}	53,0 ^{±0,4}	4	HVB 4.053	10,9	5,3
HVR 0 Nb	86,5	36 ^{±0,5}	7,0 ^{±0,5}	12,0 ^{±0,5}	62,5 ^{±0,5}	15	HVB 4.054	31,6	10,5
HVR 1 Nb	103,2	40,0 ^{±0,8}	7,7 ^{±0,5}	16,2 ^{±0,5}	70,8 ^{±0,5}	15	HVB 4.055	52,9	14,8
HVR 2 Nb	121,3	41,0 ^{±0,8}	10,8 ^{±0,5}	21,3 ^{±0,5}	78,7 ^{±0,5}	15	HVB 4.056/57	81,2	20,9
HVR 3 Nb	135,4	53,0 ^{±0,8}	12,7 ^{±0,5}	23,0 ^{±0,5}	84,9 ^{±0,75}	15	HVB 4.058/59/60	127,6	28,6
HVR 4 Nb	157,2	61,2 ^{±0,8}	14,0 ^{±0,5}	24,4 ^{±0,5}	108,4 ^{+0,8/-0,7}	15	HVB 4.061	189,6	36,0
HVR 5 Nb	175,0	66,2 ^{±0,8}	16,2 ^{±0,5}	25,6 ^{±0,5}	123,8 ^{±0,5}	15	HVB 4.062	249,2	42,8
HVR 6 Nb	201,5	71,2 ^{±0,8}	19,4 ^{±0,5}	25,7 ^{±0,5}	150,1 ^{±0,5}	20	HVB 4.063	340,5	52,3

Montážní patky

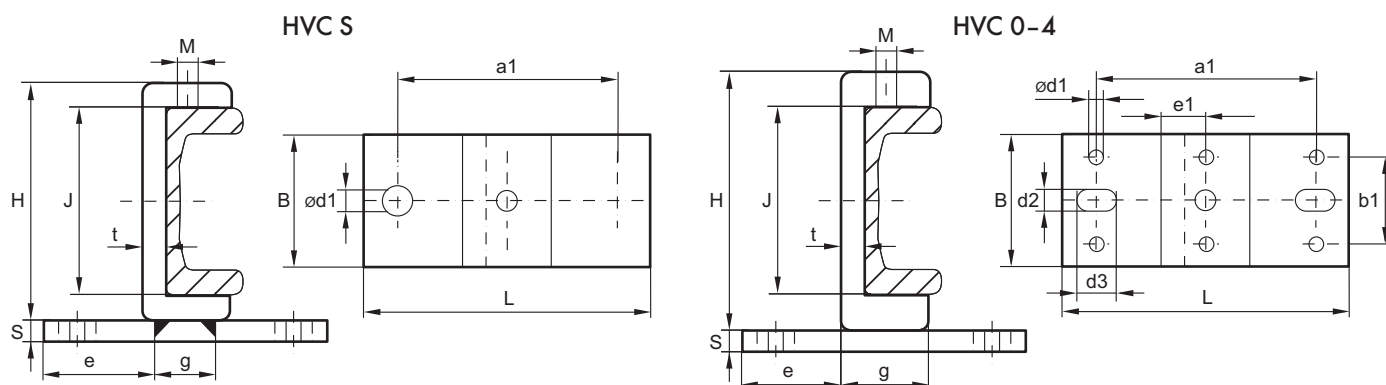

Označení	Rozměry [mm]															Kolejnice	Hmot. [kg]
	H	B	L	S	J	e	g	t	a1	b1	d1	d2	d3	e1	M		
HVC S	83,0	50	100	8	67,0	41,0	40,0	8,0	70			12			M8	HVR S	0,50
HVC 0	121,3	60	130	10	88,5	44,5	41,0	10,8	100	40	6	11	18	20,5	M10 × 30	HVR 0 Nb	1,60
HVC 1	135,4	60	130	10	105,0	38,5	53,0	12,7	100	40	6	11	18	26,5	M10 × 30	HVR 1 Nb	1,95
HVC 2	157,2	80	160	15	123,0	49,4	61,2	14,0	130	60	6	13	18	30,6	M12 × 35	HVR 2 Nb	3,85
HVC 3	175,0	80	160	15	137,5	46,9	66,2	16,2	130	60	6	13	18	33,1	M12 × 35	HVR 3 Nb	4,30
HVC 4	201,5	80	160	15	159,0	44,4	71,2	19,4	130	60	6	13	18	35,6	M12 × 35	HVR 4 Nb	5,20

Lineární vedení IBC



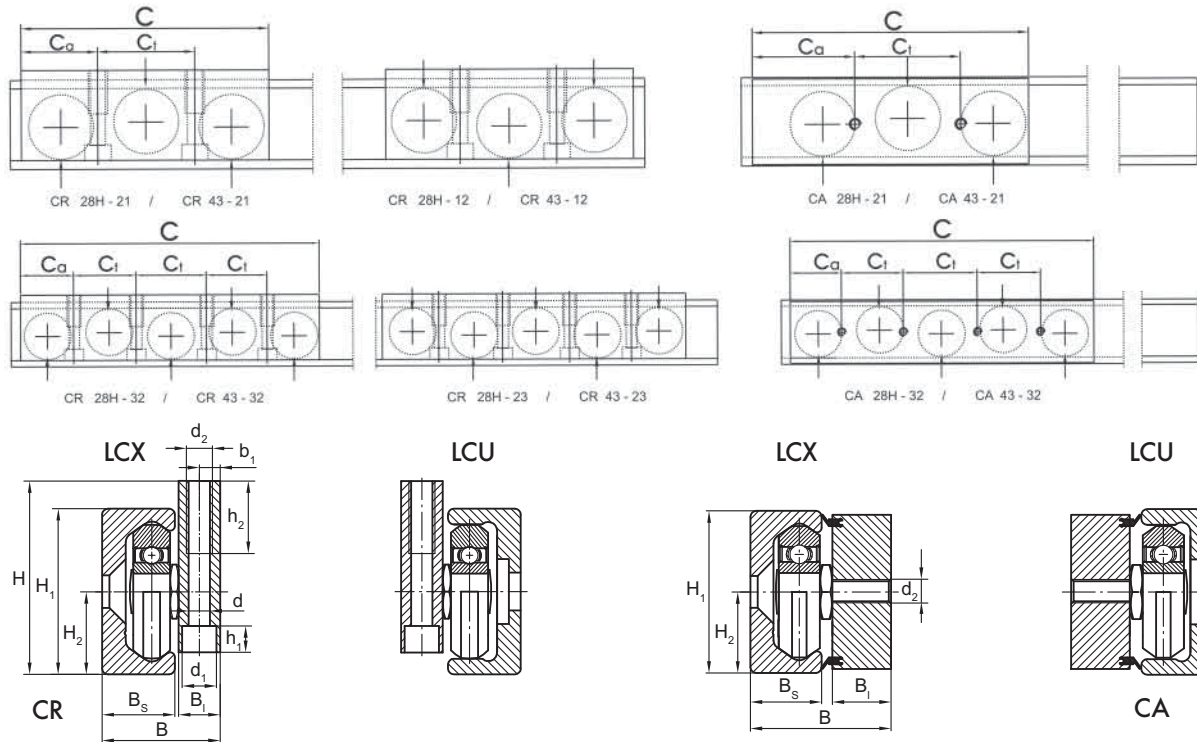

Označení		Počet vodících rolen	Rozměry [mm]														
Hlavní směr zatížení			H	H ₁	B	B _s	B ₁	d	d ₁	h ₂	C _i	C	d ₂	b ₁	C _o	H ₂	h ₁
↓	↑																
CR28H-21	CR28H-12	3	32	28	24,5	12,3	10	5,2	9	10	36	80	M6*	5	22	14	5,5
CR28H-32	CR28H-23	5	32	28	24,5	12,3	10	5,2	9	10	27	125	M6*	5	22	14	5,5
CR43-21	CR43-12	3	47	43	37,5	21	15	6,7	11	16	56	120	M8**	7,5	32	21,5	6,5
CR43-32	CR43-23	5	47	43	37,5	21	15	6,7	11	16	42	190	M8**	7,5	32	21,5	6,5
CA28H-21	***	3	*	28	24,5	12,3	10	*	*	*	36	80	M6*	*	22	14	*
CA28H-22A		4	*	28	24,5	12,3	10	*	*	*	28	100	M6*	*	22	14	*
CA28H-22B		4	*	28	24,5	12,3	10	*	*	*	28	100	M6*	*	22	14	*
CA28H-32		5	*	28	24,5	12,3	10	*	*	*	27	125	M6*	*	22	14	*
CA28H-41		5	*	28	24,5	12,3	10	*	*	*	27	125	M6*	*	22	14	*
CA28H-33A		6	*	28	24,5	12,3	10	*	*	*	27	150	M6*	*	21	14	*
CA28H-33B			*	28	24,5	12,3	10	*	*	*	27	150	M6*	*	21	14	*
CA43-21		3	*	43	37,5	21	15	*	*	*	56	120	M8*	*	32	21,5	*
CA43-32		5	*	43	37,5	21	15	*	*	*	42	190	M8*	*	32	21,5	*

Hlavní směr zatížení vozíků			Únosnost [N]			Moment [Nm]		
CA ↓	CR ↓	CR ↑	C	C _{o rad}	C _{o ax}	M _x	M _y	M _z
CA28H-21	CR28H-21	CR28-12	3085	1815	365	3,6	24,5	8,3
CA28H-32	CR28H-32	CR28-23	3670	2155	515	6,6	73,5	16,6
CA43-21	CR43-21	CR43-12	8420	4900	1085	16,2	100	37,4
CA43-32	CR43-32	CR43-23	10000	5830	1530	29,9	300	74,9

* V opačném směru možno použít šroub M5/DIN 912
 ** V opačném směru možno použít šroub M6/DIN 912
 *** Typ CA je možné po otočení o 180° montovat i pro opačný směr zatížení
 Verze A 1. rolna s centrickým čepem
 Verze B 1. rolna s excentrickým čepem

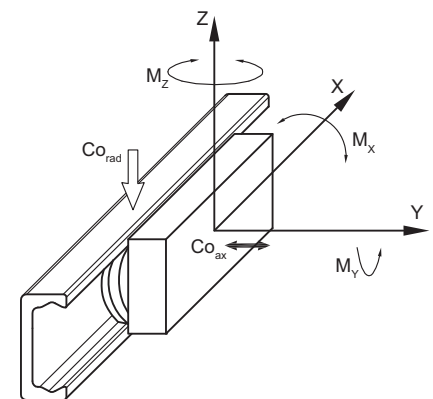

Objednací číslo:





Kolejnice

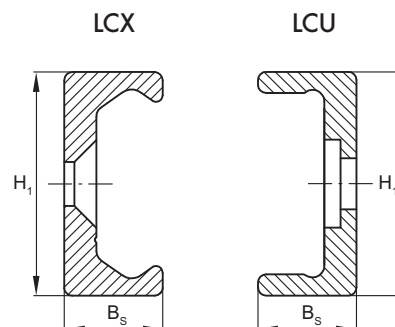
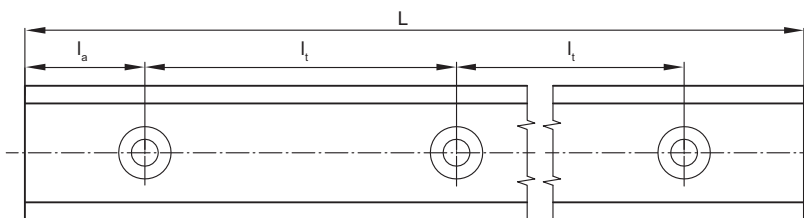

Označení	Rozměry [mm]		Zahloubení upevňovacích otvorů	
	Bs	H1	V – Kuželové	C – Válcové
Profil 28H	12,3	28	M5 DIN 7991	M5 TORX
Profil 43	21	43	M8 DIN 7991	M8 TORX

LCX/LCU 28H							
Rozměry [mm]			Hmot. [kg]	Rozměry [mm]			Hmot. [kg]
L	la	lt		L	la	lt	
240	40	80	0,26	1760	40	80	1,94
320	40	80	0,35	1840	40	80	2,02
400	40	80	0,44	1920	40	80	2,11
480	40	80	0,53	2000	40	80	2,2
560	40	80	0,62	2080	40	80	2,29
640	40	80	0,7	2160	40	80	2,38
720	40	80	0,79	2240	40	80	2,46
800	40	80	0,88	2320	40	80	2,55
880	40	80	0,97	2400	40	80	2,64
960	40	80	1,06	2480	40	80	2,73
1040	40	80	1,14	2560	40	80	2,82
1120	40	80	1,23	2640	40	80	2,9
1200	40	80	1,32	2720	40	80	2,99
1280	40	80	1,41	2800	40	80	3,08
1360	40	80	1,5	2880	40	80	3,17
1440	40	80	1,58	2960	40	80	3,26
1520	40	80	1,67	3040	40	80	3,34
1600	40	80	1,76	3120	40	80	3,43
1680	40	80	1,85	3200	40	80	3,52

LCX/LCU 43							
Rozměry [mm]			Hmot. [kg]	Rozměry [mm]			Hmot. [kg]
L	la	lt		L	la	lt	
400	40	160	1,08	2080	40	80	5,64
480	40	80	1,3	2160	40	160	5,85
560	40	160	1,52	2240	40	80	6,07
640	40	80	1,73	2320	40	160	6,29
720	40	160	1,95	2400	40	80	6,5
800	40	80	2,17	2480	40	160	6,72
880	40	160	2,38	2560	40	80	6,94
960	40	80	2,6	2640	40	160	7,15
1040	40	160	2,82	2720	40	80	7,37
1120	40	80	3,04	2800	40	160	7,59
1200	40	160	3,25	2880	40	80	7,8
1280	40	80	3,47	2960	40	160	8,02
1360	40	160	3,69	3040	40	80	8,24
1440	40	80	3,9	3120	40	160	8,46
1520	40	160	4,12	3200	40	80	8,67
1600	40	80	4,34	3280	40	160	8,89
1680	40	160	4,55	3360	40	80	9,11
1760	40	80	4,77	3440	40	160	9,32
1840	40	160	4,99	3520	40	80	9,54
1920	40	80	5,2	3600	40	160	9,76
2000	40	160	5,42				

Objednací číslo:

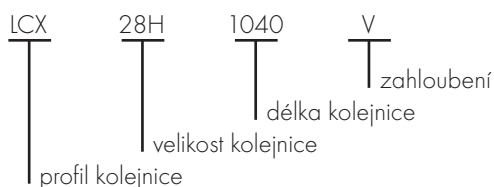

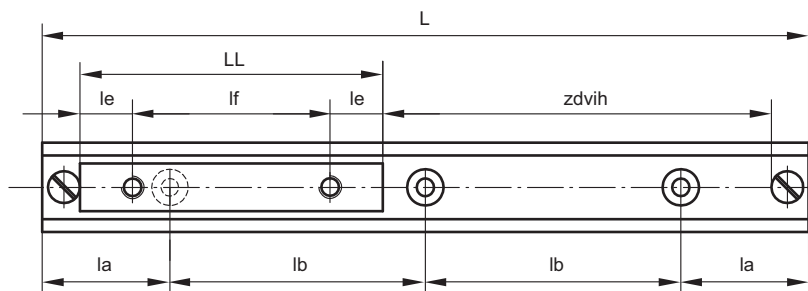
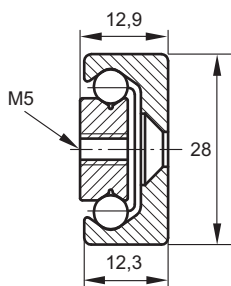

Označení	Zdvih	Rozměry [mm]						Zatížení [N]	
		Kolejnice			Vozík			C _{o rad}	C _{o ax}
		L	la	lb	LL	la	lb		
LCE 28-0130-060	30	130	25	80	60			3584	2509
LCE 28-0210-060	110	210	25	80					
LCE 28-0290-060	190	290	25	80					
LCE 28-0370-060	270	370	25	80					
LCE 28-0450-060	350	450	25	80	80	10	20	4779	3345
LCE 28-0210-080	90	210	25	80					
LCE 28-0290-080	170	290	25	80					
LCE 28-0370-080	250	370	25	80					
LCE 28-0450-080	330	450	25	80					
LCE 28-0530-080	410	530	25	80					
LCE 28-0610-080	490	610	25	80					
LCE 28-0290-130	120	290	25	80					
LCE 28-0370-130	200	370	25	80					
LCE 28-0450-130	280	450	25	80					
LCE 28-0530-130	360	530	25	80	130			7766	5436
LCE 28-0610-130	440	610	25	80					
LCE 28-0690-130	520	690	25	80					
LCE 28-0770-130	600	770	25	80					
LCE 28-0850-130	680	850	25	80					
LCE 28-0930-130	760	930	25	80					
LCE 28-1010-130	840	1010	25	80					
LCE 28-0450-210	200	450	25	80					
LCE 28-0530-210	280	530	25	80					
LCE 28-0610-210	360	610	25	80					
LCE 28-0690-210	440	690	25	80	210			12545	8782
LCE 28-0770-210	520	770	25	80					
LCE 28-0850-210	600	850	25	80					
LCE 28-0930-210	680	930	25	80					
LCE 28-1010-210	760	1010	25	80					
LCE 28-1170-210	920	1170	25	80					
LCE 28-1330-210	1080	1330	25	80					
LCE 28-0610-290	280	610	25	80					
LCE 28-0690-290	360	690	25	80					
LCE 28-0770-290	440	770	25	80					
LCE 28-0850-290	520	850	25	80	290			17325	11774
LCE 28-0930-290	600	930	25	80					
LCE 28-1010-290	680	1010	25	80					
LCE 28-1170-290	840	1170	25	80					
LCE 28-1330-290	1000	1330	25	80					
LCE 28-1490-290	1160	1490	25	80					
LCE 28-0770-370	360	770	25	80					
LCE 28-0850-370	440	850	25	80					
LCE 28-0930-370	520	930	25	80					
LCE 28-1010-370	600	1010	25	80					
LCE 28-1170-370	760	1170	25	80	370			22104	15022
LCE 28-1330-370	920	1330	25	80					
LCE 28-1490-370	1080	1490	25	80					
LCE 28-0930-450	440	930	25	80					
LCE 28-1010-450	520	1010	25	80	450			26883	18270
LCE 28-1170-450	680	1170	25	80					
LCE 28-1330-450	840	1330	25	80					
LCE 28-1490-450	1000	1490	25	80					
LCE 28-1650-450	1160	1650	25	80					

Objednáací číslo:

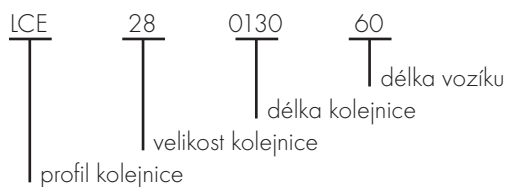

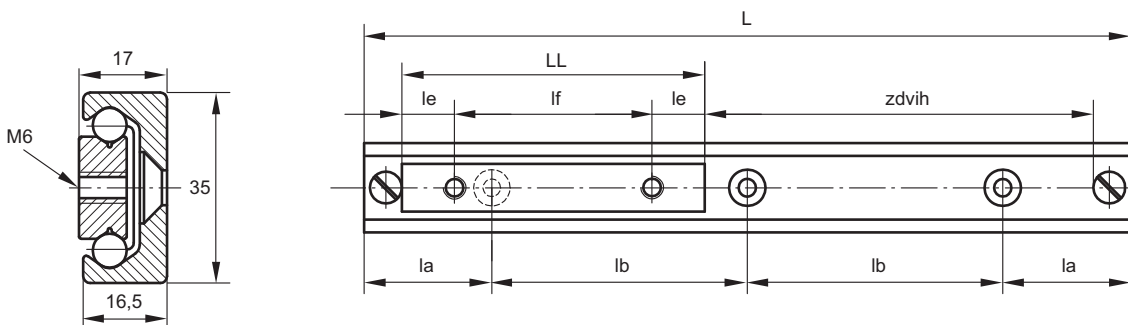

Označení	Zdvih	Rozměry [mm]						Zatížení [N]	
		Kolejnice			Vozík			C _{o rad}	C _{o ox}
		L	la	lb	LL	la	lb		
LCE 35-0290-0130	110	290							
LCE 35-0370-0130	190	370							
LCE 35-0450-0130	270	450							
LCE 35-0530-0130	350	530							
LCE 35-0610-0130	430	610							
LCE 35-0690-0130	510	690			130		9984	6988	
LCE 35-0770-0130	590	770							
LCE 35-0850-0130	670	850							
LCE 35-0930-0130	750	930							
LCE 35-1010-0130	830	1010							
LCE 35-0450-0210	190	450							
LCE 35-0530-0210	270	530							
LCE 35-0610-0210	350	610							
LCE 35-0690-0210	430	690							
LCE 35-0770-0210	510	770			210		16128	11290	
LCE 35-0850-0210	590	850							
LCE 35-0930-0210	670	930							
LCE 35-1010-0210	750	1010							
LCE 35-1170-0210	910	1170							
LCE 35-1330-0210	1070	1330							
LCE 35-1490-0210	1230	1490							
LCE 35-0610-0290	270	610							
LCE 35-0690-0290	350	690							
LCE 35-0770-0290	430	770							
LCE 35-0850-0290	510	850							
LCE 35-0930-0290	590	930							
LCE 35-1010-0290	670	1010			290		22272	15590	
LCE 35-1170-0290	830	1170	25	80		25	80		
LCE 35-1330-0290	990	1330							
LCE 35-1490-0290	1150	1490							
LCE 35-1650-0290	1310	1650							
LCE 35-0770-0370	350	770							
LCE 35-0850-0370	430	850							
LCE 35-0930-0370	510	930							
LCE 35-1010-0370	590	1010							
LCE 35-1170-0370	750	1170			370		28416	19891	
LCE 35-1330-0370	910	1330							
LCE 35-1490-0370	1070	1490							
LCE 35-1650-0370	1230	1650							
LCE 35-0930-0450	430	930							
LCE 35-1010-0450	510	1010							
LCE 35-1170-0450	670	1170							
LCE 35-1330-0450	830	1330			450		34560	24192	
LCE 35-1490-0450	990	1490							
LCE 35-1650-0450	1150	1650							
LCE 35-1810-0450	1310	1810							
LCE 35-1170-0530	590	1170							
LCE 35-1330-0530	750	1330							
LCE 35-1490-0530	910	1490			530		40704	28493	
LCE 35-1650-0530	1070	1650							
LCE 35-1810-0530	1230	1810							
LCE 35-1330-0610	670	1330							
LCE 35-1490-0610	830	1490			610		46848	32794	
LCE 35-1650-0610	990	1650							
LCE 35-1810-0610	1150	1810							

Objednací číslo:

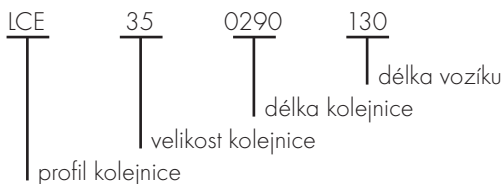

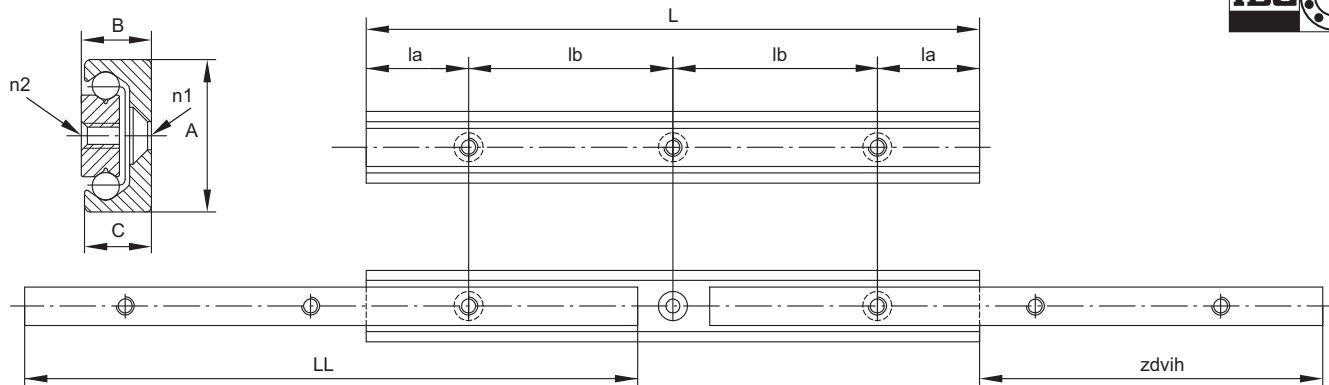

Označení	Zdvih	Rozměry [mm]								Zatížení [N]		Hmot. [kg]
		L (LL)	la	lb	A	B	C	n1	n2	C _{o,rad}	C _{o,ax}	
LCAE 28-0130	74	130	25	80	28	19,9	12,3	ø 5,5	M5	645	452	0,29
LCAE 28-0210	116	210								1165	816	0,46
LCAE 28-0290	148	290								2019	1413	0,64
LCAE 28-0370	190	370								2543	1780	0,81
LCAE 28-0450	232	450								3069	2148	0,99
LCAE 28-0530	274	530								3595	2517	1,17
LCAE 28-0610	315	610								4151	2906	1,34
LCAE 28-0690	357	690								4666	3266	1,52
LCAE 28-0770	399	770								5192	3634	1,69
LCAE 28-0850	432	850								6045	4232	1,87
LCAE 28-0930	475	930								6549	4584	2,05
LCAE 28-1010	517	1010								7074	4952	2,22
LCAE 28-1170	601	1170								8125	5688	2,57
LCAE 35-0210	127	210								1090	763	0,65
LCAE 35-0290	159	290								2101	1471	0,87
LCAE 35-0370	203	370								2686	1880	1,05
LCAE 35-0450	247	450	3271	2289	1,30							
LCAE 35-0530	279	530	4350	3045	1,55							
LCAE 35-0610	323	610	4932	3452	1,85							
LCAE 35-0690	367	690	5514	3860	2,00							
LCAE 35-0770	399	770	6614	4629	2,25							
LCAE 35-0850	443	850	7192	5035	2,55							
LCAE 35-0930	487	930	7773	5440	2,68							
LCAE 35-1010	519	1010	8882	6218	2,90							
LCAE 35-1170	607	1170	10037	7026	3,40							
LCAE 35-1330	683	1330	11728	8209	3,85							
LCAE 35-1490	759	1490	13423	9396	4,30							
LCAE 43-0210	123	210	1700	1190	1,09							
LCAE 43-0290	158	290	3033	2123	1,51							
LCAE 43-0370	208	370	3546	2482	1,92							
LCAE 43-0450	243	450	4909	3436	2,34							
LCAE 43-0530	278	530	6308	4415	2,76							
LCAE 43-0610	313	610	7728	5410	3,17							
LCAE 43-0690	363	690	8185	5730	3,59							
LCAE 43-0770	398	770	9190	6433	4,00							
LCAE 43-0850	433	850	10617	7432	4,42							
LCAE 43-0930	483	930	11477	8034	4,84							
LCAE 43-1010	518	1010	12902	9031	5,25							
LCAE 43-1170	603	1170	14774	10342	6,08							
LCAE 43-1330	688	1330	16649	11654	6,92							
LCAE 43-1490	758	1490	19094	13366	7,75							
LCAE 43-1650	843	1650	21378	14964	8,58							
LCAE 43-1810	928	1810	23249	16274	9,41							
LCAE 43-1970	1013	1970	25122	17585	10,24							

Objednací číslo:

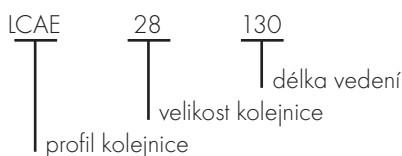

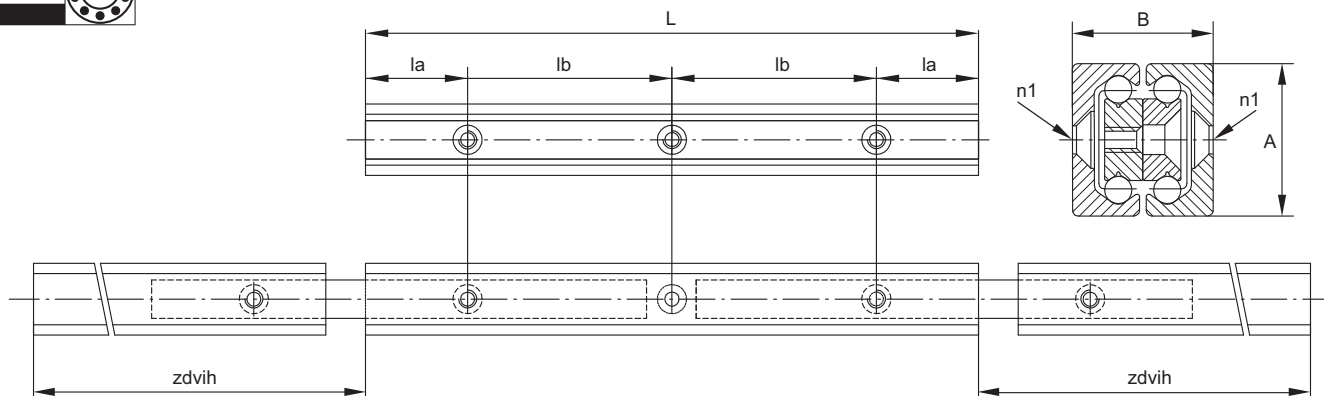

Označení	Zdvih	Rozměry [mm]					Zatížení [N]	Hmotnost [kg]	
		L	la	lb	A	B			
LCAD 28-0130	148	130	25	80	28	26	∅ 5,5	244	0,47
LCAD 28-0210	232	210						444	0,92
LCAD 28-0290	296	290						632	1,28
LCAD 28-0370	380	370						496	1,63
LCAD 28-0450	464	450						405	1,98
LCAD 28-0530	548	530						342	2,33
LCAD 28-0610	630	610						298	2,68
LCAD 28-0690	714	690						263	3,04
LCAD 28-0770	798	770						234	3,39
LCAD 28-0850	864	850						220	3,74
LCAD 28-0930	950	930						200	4,09
LCAD 28-1010	1034	1010						183	4,44
LCAD 28-1170	1202	1170						157	5,15
LCAD 35-0210	254	210						409	1,15
LCAD 35-0290	318	290						684	1,60
LCAD 35-0370	406	370						534	2,05
LCAD 35-0450	494	450	439	2,55					
LCAD 35-0530	558	530	403	3,00					
LCAD 35-0610	646	610	346	3,55					
LCAD 35-0690	734	690	304	3,90					
LCAD 35-0770	798	770	286	4,45					
LCAD 35-0850	886	850	256	4,90					
LCAD 35-0930	974	930	232	5,30					
LCAD 35-1010	1038	1010	221	5,80					
LCAD 35-1170	1214	1170	187	6,70					
LCAD 35-1330	1366	1330	169	7,60					
LCAD 35-1490	1518	1490	153	8,65					
LCAD 43-0210	246	210	631	2,33					
LCAD 43-0290	316	290	1158	3,22					
LCAD 43-0370	416	370	1349	4,11					
LCAD 43-0450	486	450	1370	5,00					
LCAD 43-0530	556	530	1229	5,88					
LCAD 43-0610	626	610	1115	6,77					
LCAD 43-0690	726	690	939	7,66					
LCAD 43-0770	796	770	870	8,55					
LCAD 43-0850	866	850	812	9,44					
LCAD 43-0930	966	930	714	10,32					
LCAD 43-1010	1036	1010	674	11,21					
LCAD 43-1170	1206	1170	576	12,99					
LCAD 43-1330	1376	1330	503	14,76					
LCAD 43-1490	1516	1490	464	16,54					
LCAD 43-1650	1686	1650	415	18,32					
LCAD 43-1810	1856	1810	376	20,09					
LCAD 43-1970	2026	1970	344	21,87					

Objednáací číslo:

LCAD 28 130
 |
 profil kolejniče
 |
 velikost kolejniče
 |
 délka vedení

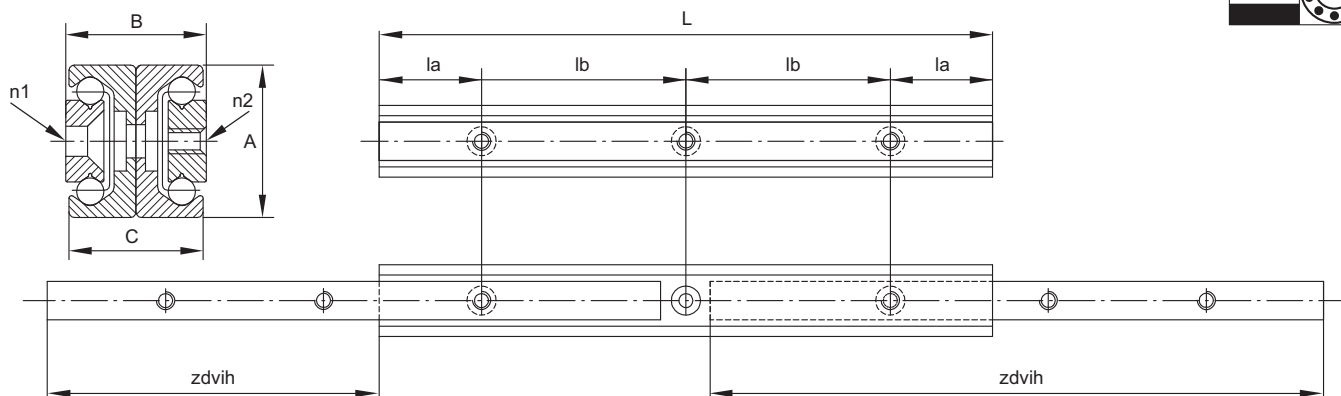

Označení	Zdvih	Rozměry [mm]								Zatížení [N]		Hmotnost [kg]
		L	la	lb	A	B	B1	n1	n2	C _{o,rad}		
LCAH 28-0130	148	130	28	80	28	26		ø 5,5	M5	244	0,57	
LCAH 28-0210	232	210								447	0,92	
LCAH 28-0290	296	290								791	1,28	
LCAH 28-0370	380	370								1001	1,63	
LCAH 28-0450	464	450								1205	1,98	
LCAH 28-0530	548	530								1140	2,33	
LCAH 28-0610	630	610								987	2,68	
LCAH 28-0690	714	690								869	3,04	
LCAH 28-0770	798	770								778	3,39	
LCAH 28-0850	864	850								734	3,74	
LCAH 28-0930	950	930								665	4,09	
LCAH 28-1010	1034	1010								610	4,44	
LCAH 28-1170	1202	1170								523	5,15	
LCAH 35-0210	254	210								409	1,20	
LCAH 35-0290	318	290	811	1,65								
LCAH 35-0370	406	370	1038	2,10								
LCAH 35-0450	494	450	1265	2,60								
LCAH 35-0530	558	530	1706	3,05								
LCAH 35-0610	646	610	1932	3,60								
LCAH 35-0690	734	690	1730	3,95								
LCAH 35-0770	798	770	1629	4,50								
LCAH 35-0850	886	850	1459	4,95								
LCAH 35-0930	974	930	1322	5,35								
LCAH 35-1010	1038	1010	1263	5,85								
LCAH 35-1170	1214	1170	1069	6,75								
LCAH 35-1330	1366	1330	959	7,65								
LCAH 35-1490	1518	1490	870	8,70								
LCAH 43-0210	246	210	631	2,21								
LCAH 43-0290	316	290	1159	3,05								
LCAH 43-0370	416	370	1349	3,89								
LCAH 43-0450	486	450	1894	4,73								
LCAH 43-0530	556	530	2460	5,57								
LCAH 43-0610	626	610	3037	6,41								
LCAH 43-0690	726	690	3197	7,25								
LCAH 43-0770	796	770	3146	8,09								
LCAH 43-0850	866	850	2932	8,93								
LCAH 43-0930	966	930	2581	9,77								
LCAH 43-1010	1036	1010	2435	10,61								
LCAH 43-1170	1206	1170	2083	12,29								
LCAH 43-1330	1376	1330	1819	13,97								
LCAH 43-1490	1516	1490	1677	15,65								
LCAH 43-1650	1686	1650	1502	17,33								
LCAH 43-1810	1856	1810	1360	19,01								
LCAH 43-1970	2026	1970	1242	20,69								

Objednáací číslo:

LCAH

28

130

GG

způsob upevnění vozíku

(GG - závit - závit, DD - průchozí otvor - průchozí otvor, GD - závit - průchozí otvor)

délka vedení

velikost kolejničky

profil kolejničky

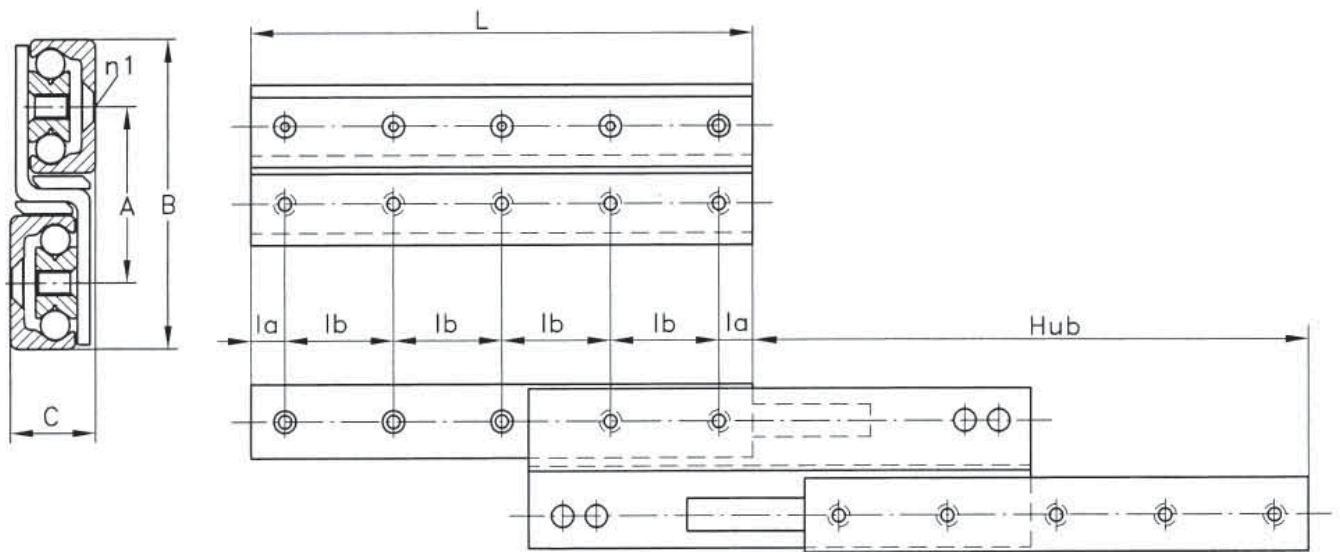

Označení	Zdvih	Rozměry [mm]							Zatížení [N]		Hmotnost [kg]					
		L	la	lb	A	B	C	n1	C _{o rad}							
LCAZ 28.E-0290	296	290	25	80	42	70	17	ø 5,5	557	2,52						
LCAZ 28.E-0370	380	370							754	3,22						
LCAZ 28.E-0450	464	450							949	3,91						
LCAZ 28.E-0530	548	530							1030	4,61						
LCAZ 28.E-0610	630	610							906	5,30						
LCAZ 28.E-0690	714	690							793	6,00						
LCAZ 28.E-0770	798	770							700	6,69						
LCAZ 28.E-0850	864	850							618	7,39						
LCAZ 28.E-0930	950	930							608	8,08						
LCAZ 28.E-1010	1034	1010							494	8,78						
LCAZ 43.E-0530	556	530							25	80	62	105	28	ø 8,5	2015	7,74
LCAZ 43.E-0610	626	610													2379	8,91
LCAZ 43.E-0690	726	690													2554	10,07
LCAZ 43.E-0770	796	770	2350	11,24												
LCAZ 43.E-0850	866	850	2112	12,41												
LCAZ 43.E-0930	966	930	1957	13,58												
LCAZ 43.E-1010	1036	1010	1648	14,75												
LCAZ 43.E-1170	1206	1170	1524	17,08												
LCAZ 43.E-1330	1376	1330	1339	19,42												
LCAZ 43.E-1490	1516	1490	1154	21,75												
LCAZ 43.E-1650	1686	1650	927	24,09												
LCAZ 43.E-1810	1856	1810	618	26,43												
LCAZ 43.E-1970	2026	1970	577	28,76												

Objednací číslo:

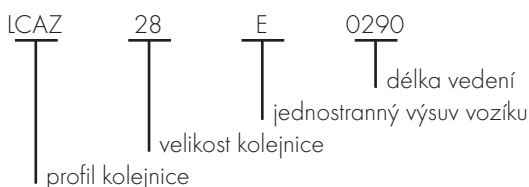

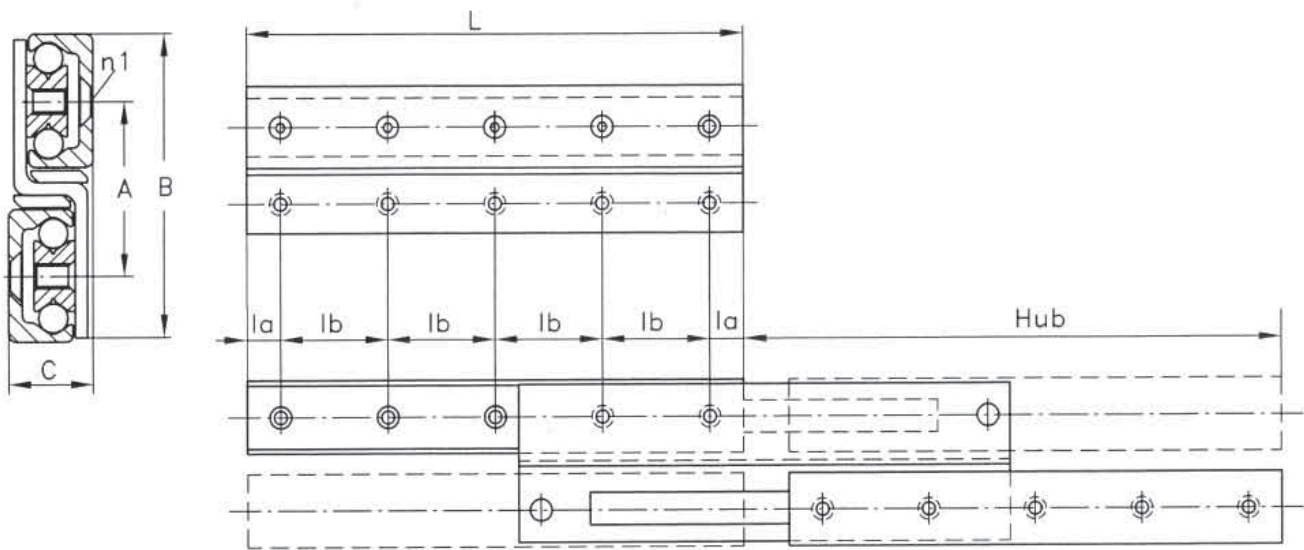

Označení	Zdvih	Rozměry [mm]							Zatížení [N]	Hmotnost [kg]
		L	la	lb	A	B	C	n1		
LCAZ 28.D-0290	246	290	25	80	42	70	17	ø 5,5	721	2,52
LCAZ 28.D-0370	326	370							948	3,22
LCAZ 28.D-0450	406	450							1154	3,91
LCAZ 28.D-0530	486	530							1339	4,61
LCAZ 28.D-0610	566	610							1318	5,30
LCAZ 28.D-0690	646	690							1009	6,00
LCAZ 28.D-0770	726	770							845	6,69
LCAZ 28.D-0850	806	850							762	7,39
LCAZ 28.D-0930	866	930							742	8,08
LCAZ 28.D-1010	966	1010							680	8,78
LCAZ 43.D-0530	476	530	25	80	62	105	28	ø 8,5	2575	7,74
LCAZ 43.D-0610	556	610							2987	8,91
LCAZ 43.D-0690	636	690							2781	10,07
LCAZ 43.D-0770	716	770							2575	11,24
LCAZ 43.D-0850	796	850							2369	12,41
LCAZ 43.D-0930	876	930							2163	13,58
LCAZ 43.D-1010	956	1010							1957	14,75
LCAZ 43.D-1170	1116	1170							1648	17,08
LCAZ 43.D-1330	1276	1330							1442	19,42
LCAZ 43.D-1490	1436	1490							1236	21,75
LCAZ 43.D-1650	1596	1650							1133	24,09
LCAZ 43.D-1810	1756	1810							1030	26,43
LCAZ 43.D-1970	1916	1970							989	28,76

Objednáací číslo:

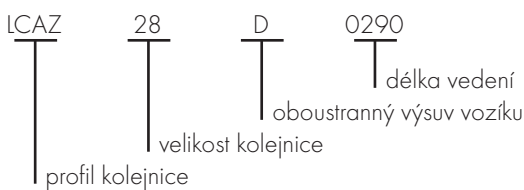

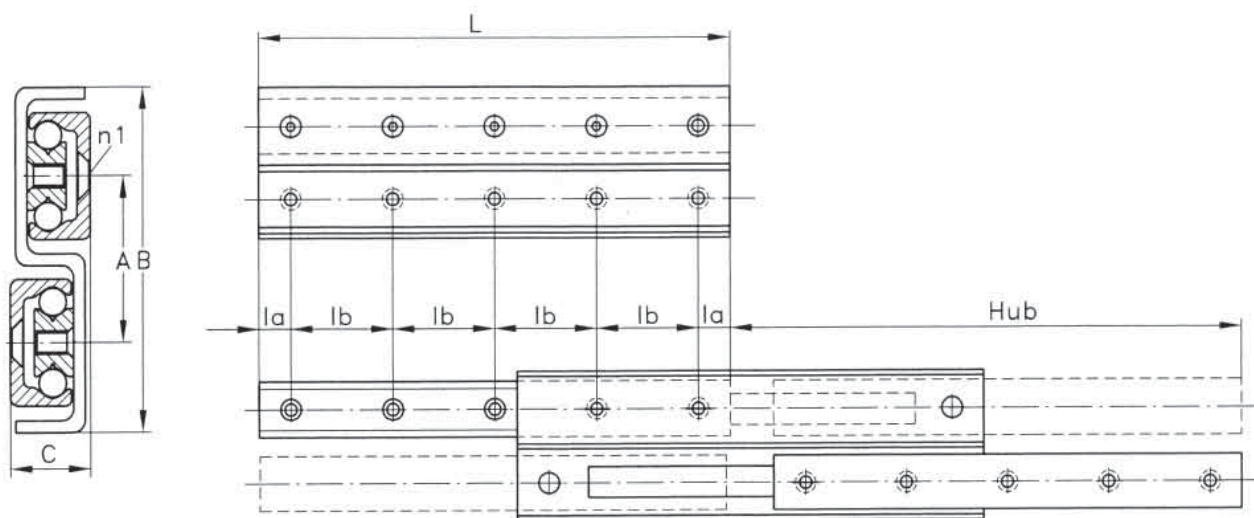

Označení	Zdvih	Rozměry [mm]							Zatížení [N]		Hmotnost [kg]
		L	la	lb	A	B	C	n1	Co rad		
LCAS 28.D-0290	246	290	25	80	35	80	17	ø 5,5	1061	2,52	
LCAS 28.D-0370	326	370							1246	3,22	
LCAS 28.D-0450	406	450							1576	3,91	
LCAS 28.D-0530	486	530							1782	4,61	
LCAS 28.D-0610	566	610							1998	5,30	
LCAS 28.D-0690	646	690							2215	6,00	
LCAS 28.D-0770	726	770							2431	6,69	
LCAS 28.D-0850	806	850							2750	7,39	
LCAS 28.D-0930	866	930							2791	8,08	
LCAS 28.D-1010	966	1010							2431	8,78	
LCAS 28.D-1170	1126	1170							2070	10,17	
LCAS 28.D-1330	1286	1330							1803	11,56	
LCAS 28.D-1490	1446	1490							1597	12,95	
LCAS 43.D-0530	476	530							25	80	52
LCAS 43.D-0610	556	610	3657	8,91							
LCAS 43.D-0690	636	690	4213	10,07							
LCAS 43.D-0770	716	770	4429	11,24							
LCAS 43.D-0850	796	850	4975	12,41							
LCAS 43.D-0930	876	930	5531	13,58							
LCAS 43.D-1010	956	1010	5747	14,75							
LCAS 43.D-1170	1116	1170	5552	17,08							
LCAS 43.D-1330	1276	1330	4831	19,42							
LCAS 43.D-1490	1436	1490	4264	21,75							
LCAS 43.D-1650	1596	1650	3821	24,09							
LCAS 43.D-1810	1756	1810	3461	26,43							
LCAS 43.D-1970	1916	1970	3172	28,76							

Objednací číslo:

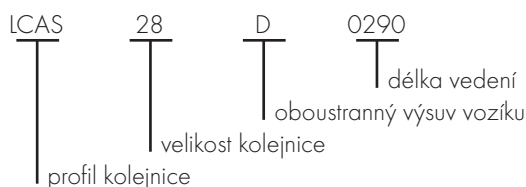

Kolejnicové lineární vedení HIWIN

HIWIN® S.r.o.
Lineartechnologie

Úzké provedení

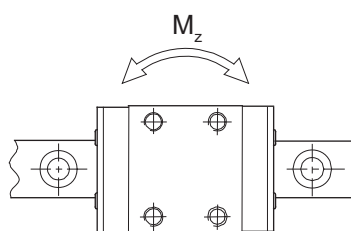
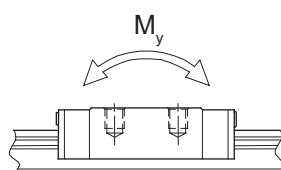
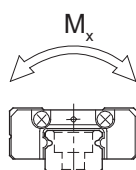
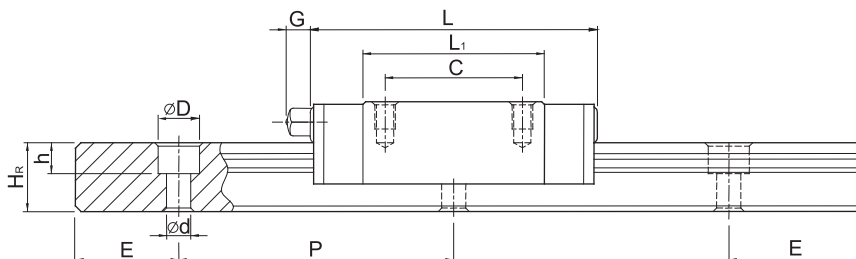
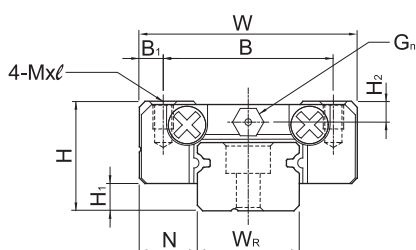
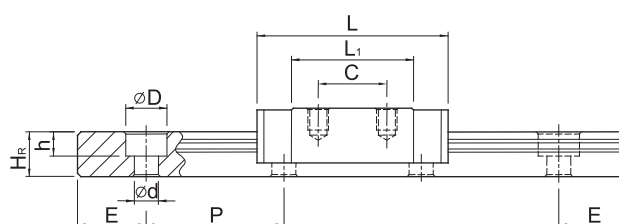
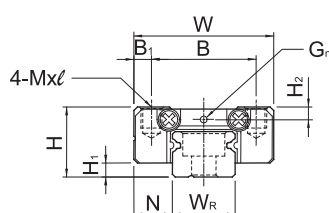

Označení	Rozměry [mm]																			Únosnost [N]		Moment [Nm]			Hmot. vozíku [g]	Hmot. kolejničky [kg/m]		
	Komplet				Vozík						Kolejnic									C _d	C ₀	M _x	M _y	M _z				
	H	H ₁	N	W	B	B ₁	C	L ₁	L	G	G _n	M × ℓ	H ₂	W _R	H _R	D	h	d	P								E	Mont. šroub
MGN7C	8	1,5	5	17	12	2,5	8	13,5	22,5		ø0,8	M2 × 2,5	1,5	7	4,8	4,2	2,3	2,4	15	5	M2 × 6	1000	1270	4,8	2,9	2,9	10	0,22
MGN7H							13	21,8	30,8													1400	2000	7,8	4,9	4,9	15	
MGN9C	10	2	5,5	20	15	2,5	10	18,9	28,9		ø0,8	M3 × 3	1,8	9	6,5	6	3,5	3,5	20	7,5	M3 × 8	1900	2600	12	7,5	7,5	16	0,38
MGN9H							16	29,9	39,9													2600	4100	20	19	19	26	
MGN12C	13	3	7,5	27	20	3,5	15	21,7	34,7		ø0,8	M3 × 3,5	2,5	12	8	6	4,5	3,5	25	10	M3 × 8	2900	4000	26	14	14	34	0,65
MGN12H							20	32,4	45,4													3800	6000	39	37	37	54	
MGN15C	16	4	8,5	32	25	3,5	20	26,7	42,1		4,5 GN3S	M3 × 4	3	15	10	6	4,5	3,5	40	15	M3 × 10	4700	5700	46	22	22	59	1,06
MGN15H							25	43,4	58,8													6500	9300	75	59	59	92	

*Pokud zákazník neurčí jinak, oba konce E1 a E2 jsou symetrické. Při objednání prosíme o stanovení vzdálenosti prvního otvoru od začátku kolejničky. Formou E1 = . . mm.

Široké provedení

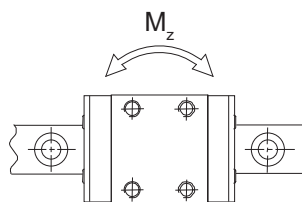
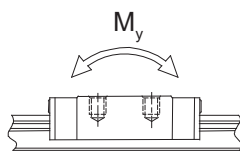
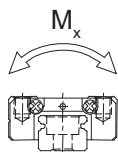
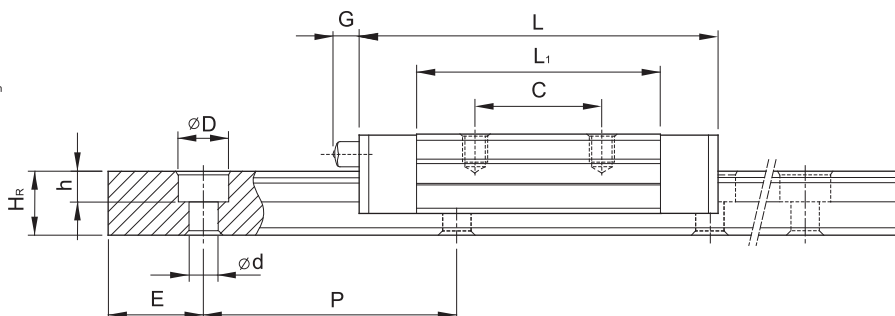
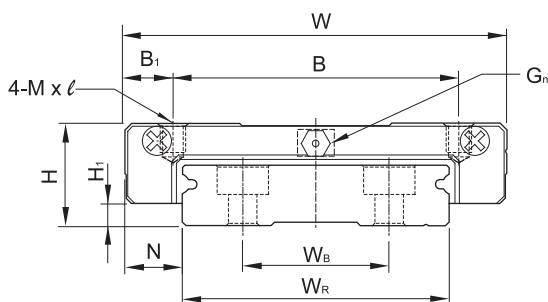
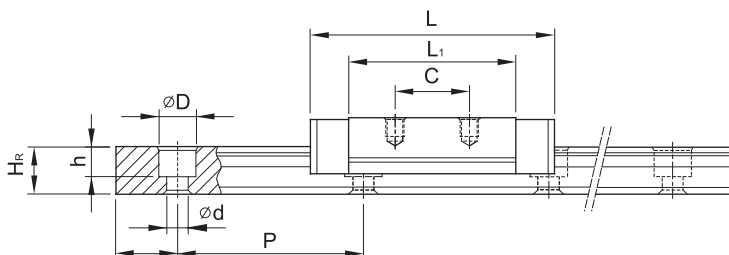
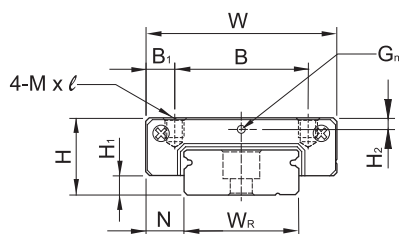

Označení	Rozměry [mm]																			Únosnost [N]		Moment [Nm]			Hmot. vozíku [g]	Hmot. kolej. [kg/m]			
	Komplet		Vozík							Kolejnic										Mont. šroub	Cd	Co	Mx	My			Mz		
	H	Hi	N	W	B	B1	C	L1	L	G	Gn	M x l	H2	WR	WB	Hr	D	h	d									P	E
MGW7C	9	1,9	5,5	25	19	3	10	21	31,2		∅0,9	M3 x 3	1,85	14		5,2	6	3,2	3,5	30	10	M3 x 6	1400	2100	16	7,3	7,3	20	0,51
MGW7H							19	30,8	41													M3 x 6	1800	3200	23,9	15,8	15,8	29	
MGW9C	12	2,9	6	30	21	4,5	12	27,5	39,3		∅1,0	M3 x 3	2,4	18		7	6	4,5	3,5	30	10	M3 x 8	2800	4200	40,9	19,3	19,3	40	0,91
MGW9H					23	3,5	24	38,5	50,7													M3 x 8	3500	6000	55,6	34,7	34,7	57	
MGW12C	14	3,4	8	40	28	6	15	31,3	46,1		∅1,8	M3 x 3,6	2,8	24		8,5	8	4,5	4,5	40	15	M4 x 8	4000	5700	71,7	28,3	28,3	71	1,49
MGW12H							28	45,6	60,4													M4 x 8	5200	8400	104,7	58,5	58,5	103	
MGW15C	16	3,4	9	60	45	7,5	20	38	54,8		5,2 GN3S	M4 x 4,2	3,2	42	23	9,5	8	4,5	4,5	40	15	M4 x 10	6900	9400	203,2	57,8	57,8	143	2,86
MGW15H							35	57	73,8													M4 x 10	9100	14100	304,8	125	125	215	

* Pokud zákazník neurčí jinak, oba konce E1 a E2 jsou symetrické. Při objednání prosíme o stanovení vzdálenosti prvního otvoru od začátku kolejnice. Formou E1 = .. mm.

Úzké provedení

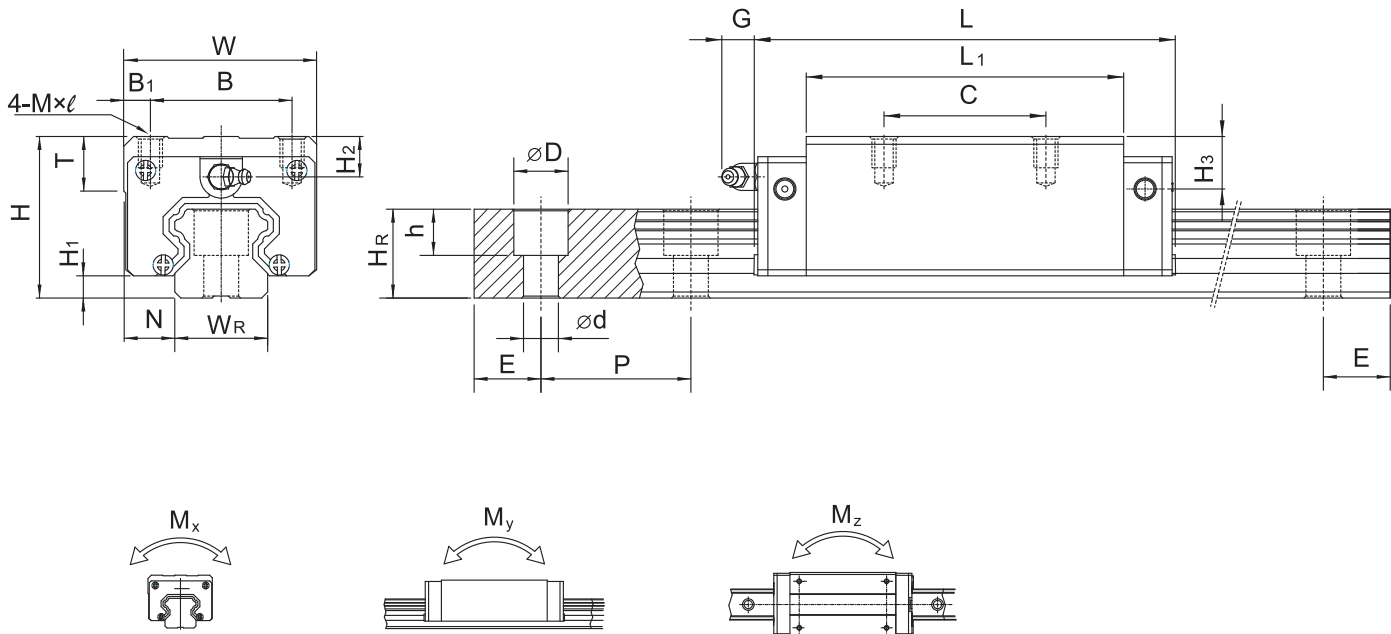
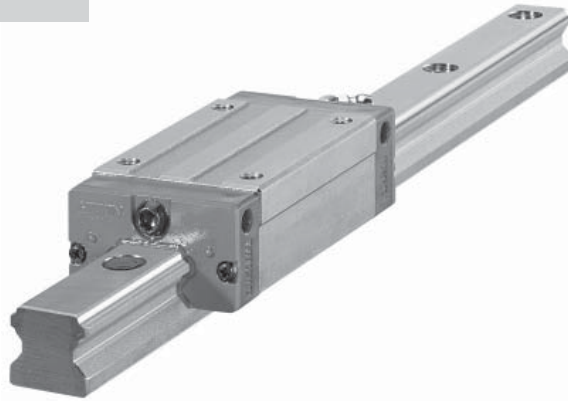

Označení	Rozměry [mm]																				Únosnost [N]		Moment [Nm]			Hmot. vozíku [g]	Hmot. kolej. [kg/m]		
	Komplet				Vozík						Kolejnic										Mont. šroub	Cd	C0	Mx	My			Mz	
	H	H1	N	W	B	B1	C	L1	L	G	M x l	T	H2	H3	WR	Hr	D	h	d	P									E
HGH15CA	28	4,3	9,5	34	26	4	26	39,4	61,4	5,3	M4 x 5	6	8,5	9,5	15	15	7,5	5,3	4,5	60	20	M4 x 16	11,380	25,310	170	150	150	0,18	1,45
HGH20CA	30	4,6	12	44	32	6	36	50,5	75,6	12	M5 x 6	8	6	7	20	17,5	9,5	8,5	6	60	20	M5 x 16	17,750	37,840	380	270	270	0,38	2,21
HGH20HA							50	65,2	90,3														21,180	48,840	480	470	470	0,39	
HGH25CA	40	5,5	12,5	48	35	6,5	35	58	83	12	M6 x 8	8	10	13	23	22	11	9	7	60	20	M6 x 20	26,480	56,190	640	510	510	0,67	3,21
HGH25HA							50	78,6	103,6														32,750	76,000	870	880	880	0,69	
HGH30CA	45	6	16	60	40	10	40	70	97,4	12	M8 x 10	8,5	9,5	13,8	28	26	14	12	9	80	20	M8 x 25	38,740	83,060	1,060	850	850	1,14	4,47
HGH30HA							60	93	120,4														47,270	110,130	1,400	1,470	1,470	1,16	
HGH35CA	55	7,5	18	70	50	10	50	80	112,4	12	M8 x 12	10,2	16	19,6	34	29	14	12	9	80	20	M8 x 25	49,520	102,870	1,730	1,200	1,200	1,88	6,3
HGH35HA							72	105,8	138,2														60,210	136,310	2,290	2,080	2,080	1,92	
HGH45CA	70	9,5	20,5	86	60	13	60	97	138	12,9	M10 x 17	16	18,5	30,5	45	38	20	17	14	105	22,5	M12 x 35	77,570	155,930	3,010	2,350	2,350	3,54	10,41
HGH45HA							80	128,8	169,8														94,540	207,120	4,000	4,070	4,070	3,61	
HGH55CA	80	13	23,5	100	75	12,5	75	117,7	165,7	12,9	M12 x 18	17,5	22	29	53	44	23	20	16	120	30	M14 x 45	114,440	227,810	5,660	4,060	4,060	5,38	15,08
HGH55HA							95	155,8	203,8														139,350	301,206	7,490	7,010	7,010	5,49	
HGH65CA	90	15	31,5	126	76	25	70	144,2	198,2	12,9	M16 x 20	25	15	15	63	53	26	22	18	150	35	M16 x 50	163,630	324,710	10,020	6,440	6,440	7,00	21,18
HGH65HA							120	203,6	257,6														208,306	457,150	14,150	11,120	11,120	9,82	

*Pokud zákazník neurčí jinak, oba konce E1 a E2 jsou symetrické. Při objednání prosíme o stanovení vzdálenosti prvního otvoru od začátku kolejnice. Formou E1 = . mm.

Provedení se sníženou zástavbovou výškou

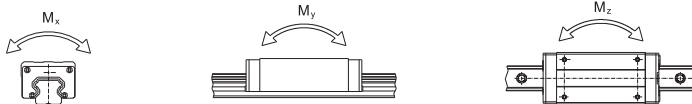
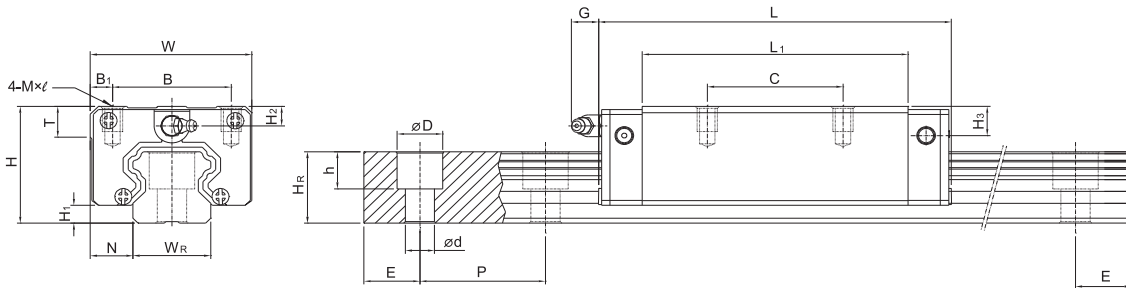
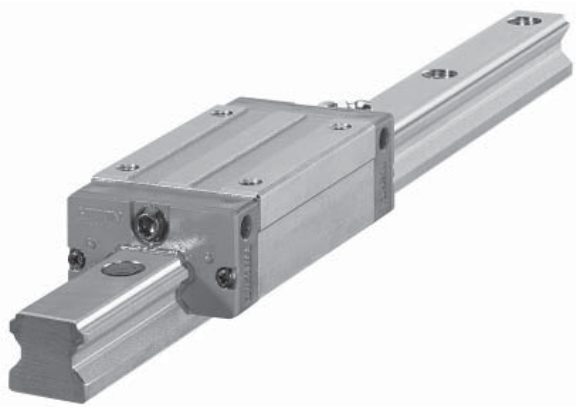

Označení	Rozměry [mm]																				Únosnost [N]		Moment [Nm]			Hmot. vozíku [g]	Hmot. kolej. [kg/m]	
	Komplet					Vozík					Kolejnic										Mont. šroub	Cd	Co	Mx	My			Mz
	H	H1	N	W	B	B1	C	L1	L	G	M × l	H2	H3	WR	Hr	D	h	d	P	E								
HGL15CA	24	6,3	9,5	34	26	4	26	39,4	61,4	5,3	M4 × 4	4,5	5,5	15	15	7,5	5,3	4,5	60	20	M4 × 16	11380	25310	170	150	150	0,14	1,45
HGL25CA	36	5,5	12,5	48	35	6,5	35	58	84	12	M6 × 6	6	9	23	22	11	9	7	60	20	M6 × 20	26480	56190	640	510	510	0,42	3,21
HGL25HA							50	78,6	104,6													32750	76000	870	880	880	0,57	
HGL30CA	42	6	16	60	40	10	40	70	97,4	12	M8 × 10	6,5	10,8	28	26	14	12	9	80	20	M8 × 25	38740	83060	1060	850	850	0,78	4,47
HGL30HA							60	93	120,4													47270	110130	1400	1470	1470	1,03	
HGL35CA	48	7,5	18	70	50	10	50	80	112,4	12	M8 × 12	9	12,6	34	29	14	12	9	80	20	M8 × 25	49520	102870	1730	1200	1200	1,14	6,30
HGL35HA							72	105,8	138,2													60210	136310	2290	2080	2080	1,52	
HGL45CA	60	9,5	20,5	86	60	13	60	97	139,4	12,9	M10 × 17	8,5	20,8	45	38	20	17	14	105	22,5	M12 × 35	77570	155930	3010	2350	2350	2,08	10,41
HGL45HA							80	128,8	171,2													94540	207120	4000	4070	4070	2,75	
HGL55CA	70	13	23,5	100	75	12,5	75	117,7	166,7	12	M12 × 18	12	19	53	44	23	20	16	120	30	M14 × 45	114440	227810	5660	4060	4060	3,25	15,08
HGL55HA							80	155,8	204,8													139350	301260	7490	7010	7010	4,27	

* Pokud zákazník neurčí jinak, oba konce E1 a E2 jsou symetrické. Při objednání prosíme o stanovení vzdálenosti prvního otvoru od začátku kolejnice. Formou E1 = .. mm.

Přírubové provedení

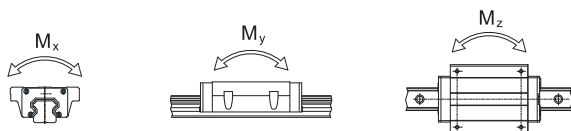
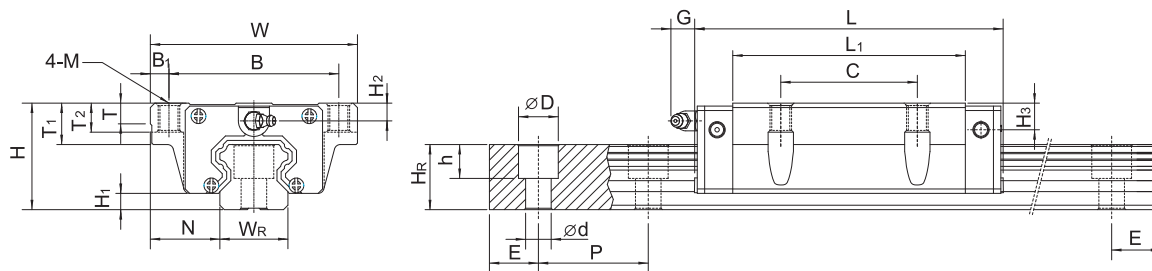
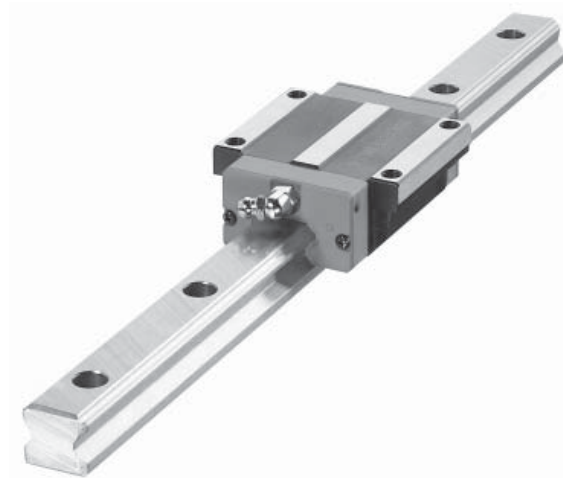

Označení	Rozměry [mm]																							Únosnost [N]		Moment [Nm]			Hmot. vozíku [g]	Hmot. kolej. [kg/m]	
	Komplet			Vozík										Kolejnic										Mont. šroub	C _d	C _o	M _x	M _y			M _z
	H	H ₁	N	W	B	B ₁	C	L ₁	L	G	M	T	T ₁	T ₂	H ₂	H ₃	W _R	H _R	D	h	d	P	E								
HGW15CC	24	4,3	16	47	38	4,5	30	39,4	61,4	5,3	M5	6	8,9	6,95	4,5	5,5	15	15	7,5	5,3	4,5	60	20	M4 × 16	11,380	25,310	170	150	150	0,17	1,45
HGW20CC	30	4,6	21,5	63	53	5	40	50,5	75,6	12	M6	8	10	9,5	6	7	20	17,5	9,5	8,5	6	60	20	M5 × 16	17,750	37,840	380	270	270	0,51	2,21
HGW20HC								65,2	90,3																21,180	48,840	480	470	470	0,52	
HGW25CC	36	5,5	23,5	70	57	6,5	45	58	83	12	M8	8	14	10	6	9	23	22	11	9	7	60	20	M6 × 20	26,480	56,190	640	510	510	0,78	3,21
HGW25HC								78,6	103,6																32,750	76,000	870	880	880	0,80	
HGW30CC	42	6	31	90	72	9	52	70	97,4	12	M10	8,5	16	10	6,5	10,8	28	26	14	12	9	80	20	M8 × 25	38,740	83,060	1,060	850	850	1,42	4,47
HGW30HC								93	120,4																47,270	110,130	1,400	1,470	1,470	1,44	
HGW35CC	48	7,5	33	100	82	9	62	80	112,4	12	M10	10,1	18	13	9	12,6	34	29	14	12	9	80	20	M8 × 25	49,520	102,870	1,730	1,200	1,200	2,03	6,3
HGW35HC								105,8	138,2																60,210	136,310	2,290	2,080	2,080	2,06	
HGW45CC	60	9,5	37,5	120	100	10	80	97	138	12,9	M12	15,1	22	15	8,5	20,5	45	38	20	17	14	105	22,5	M12 × 35	77,570	155,930	3,010	2,350	2,350	3,54	10,41
HGW45HC								128,8	169,8																94,540	207,120	4,000	4,070	4,070	3,69	
HGW55CC	70	13	43,5	140	116	12	95	117,7	165,7	12,9	M14	17,5	26,5	17	12	19	53	44	23	20	16	120	30	M14 × 45	114,440	227,810	5,660	4,060	4,060	5,38	15,08
HGW55HC								144,2	198,2																139,350	301,260	7,490	7,010	7,010	5,96	
HGW65CC	90	15	53,5	170	142	14	110	144,2	198,2	12,9	M16	25	37,5	23	15	15	63	53	26	22	18	150	35	M16 × 50	163,630	324,710	10,020	6,440	6,440	9,17	21,18
HGW65HC								203,6	257,6																208,360	457,150	14,150	11,120	11,120	12,89	

*Pokud zákazník neurčí jinak, oba konce E1 a E2 jsou symetrické. Při objednání prosíme o stanovení vzdálenosti prvního otvoru od začátku kolejnice. Formou E1 = . mm.

Úzké provedení

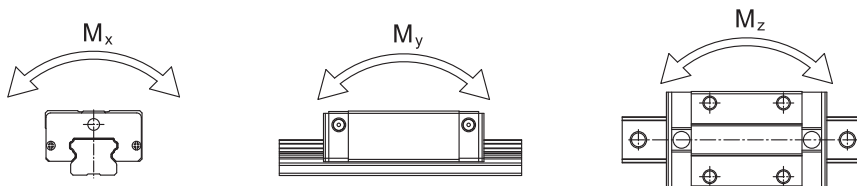
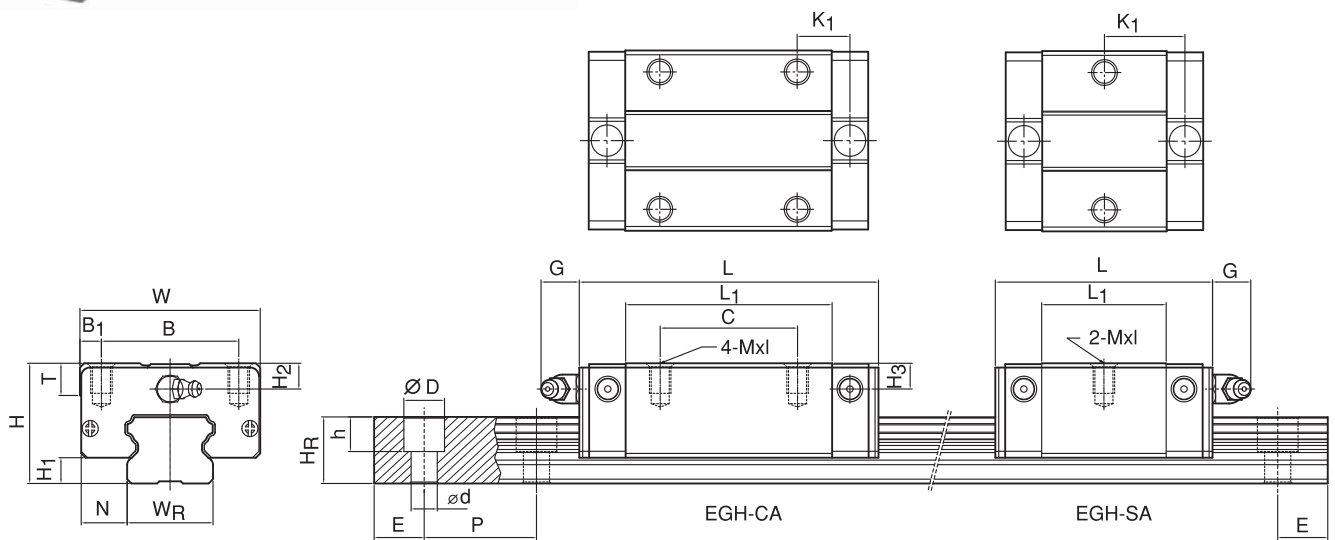
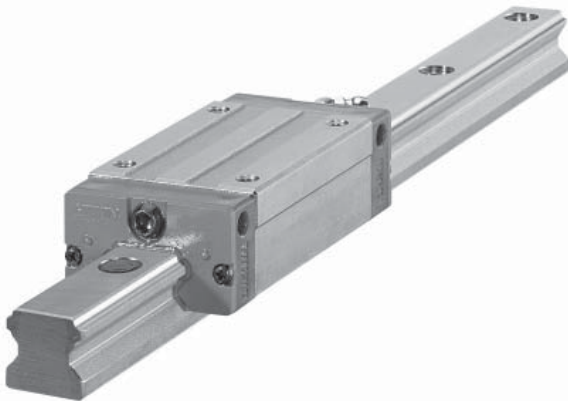

Označení	Rozměry [mm]																				Únosnost [N]		Moment [Nm]			Hmot. vozíku [g]	Hmot. kolej. [kg/m]		
	Komplet					Vozík							Kolejnic								Mont. šroub	C _d	C ₀	M _x	M _y			M _z	
	H	H ₁	N	W	B	B ₁	C	L ₁	L	G	M × l	K ₁	T	H ₂	H ₃	W _R	H _R	D	h	d									P
EGH15SA	24	4,5	9,5	34	26	4	23,1	40,7	5,7	M4 × 6	14,8	6	5,5	6	15	12,5	6	4,5	3,5	60	*	M3 × 16	5,35	9,40	80	40	40	0,09	1,25
EGH15CA							26	39,8	57,4		10,15												7,83	16,19	130	100	100	0,15	
EGH20SA	28	6	11	42	32	5	29	50,6	12	M5 × 7	18,75	7,5	6	6	20	15,5	9,5	8,5	6	60	*	M5 × 16	7,23	12,74	130	60	60	0,15	2,08
EGH20CA							32	48,1	69,7		12,3												10,31	21,13	220	160	160	0,24	
EGH25SA	33	7	12,5	48	35	6,5	35,5	61,1	12	M6 × 9	21,9	8	8	8	23	18	11	9	7	60	*	M6 × 20	11,40	19,50	230	120	120	0,25	2,67
EGH25CA							35	59	84,6		16,15												16,27	32,40	380	320	320	0,41	
EGH30SA	42	10	16	60	40	10	41,5	71,5	12	M8 × 12	26,75	9	8	9	28	23	11	9	7	80	*	M6 × 25	16,42	28,10	400	210	210	0,45	4,35
EGH30CA							40	70,1	100,1		21,05												23,70	47,46	680	550	550	0,76	

* Pokud zákazník neurčí jinak, oba konce E1 a E2 jsou symetrické. Při objednání prosíme o stanovení vzdálenosti prvního otvoru od začátku kolejnice. Formou E1 = .. mm.

Přírubové provedení

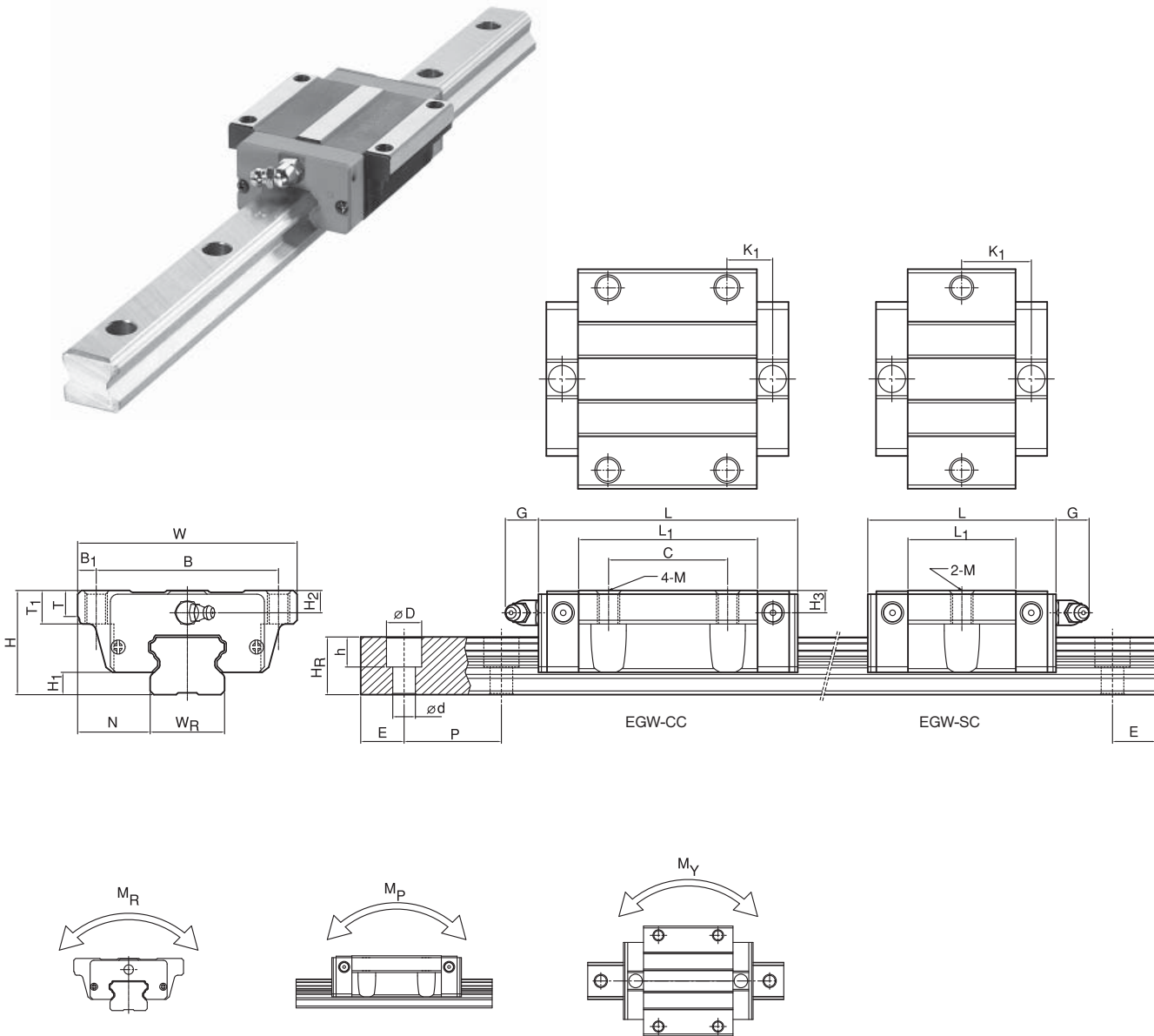

Označení	Rozměry [mm]																									Únosnost [N]		Moment [Nm]			Hmot. vozíku [g]	Hmot. kolej. [kg/m]
	Komplet					Vozík							Kolejnic										Mont. šroub									
	H	H ₁	N	W	B	B ₁	C	L ₁	L	G	M	K ₁	T	T ₁	H ₂	H ₃	W _R	H _R	D	h	d	P		E	C _d	C ₀	M _x	M _y	M _z			
EGW15SC	24	4,5	18,5	52	41	5,5	23,1	40,7	5,7	M5	14,8	5	7	5,5	6	15	12,5	6	4,5	3,5	60	*	M3×16	5,35	9,40	80	40	40	0,12	1,25		
EGW15CC							26	39,8	57,4		10,15													7,83	16,19	130	100	100	0,21			
EGW20SC	28	6	19,5	59	49	5	29	50,6	12	M6	18,75	7	9	6	6	20	15,5	9,5	8,5	6	60	*	M5×16	7,23	12,74	130	60	60	0,19	2,08		
EGW20CC							32	48,1	69,7		12,3													10,31	21,13	220	160	160	0,32			
EGW25SC	33	7	25	73	60	6,5	35,5	61,1	12	M8	21,9	7,5	10	8	8	23	18	11	9	7	60	*	M6×20	11,40	19,50	230	120	120	0,35	2,67		
EGW25CC							35	59	84,6		16,15													16,27	32,40	380	320	320	0,59			
EGW30SC	42	10	31	90	72	9	41,5	71,5	12	M10	26,75	7	10	8	9	28	23	11	9	7	80	*	M6×25	16,42	28,10	400	210	210	0,62	4,35		
EGW30CC							40	70,1	100,1		21,05													23,70	47,46	680	550	550	1,04			

*Pokud zákazník neurčí jinak, oba konce E1 a E2 jsou symetrické. Při objednání prosíme o stanovení vzdálenosti prvního otvoru od začátku kolejnice. Formou E1 = . mm.

Široké provedení – úzké

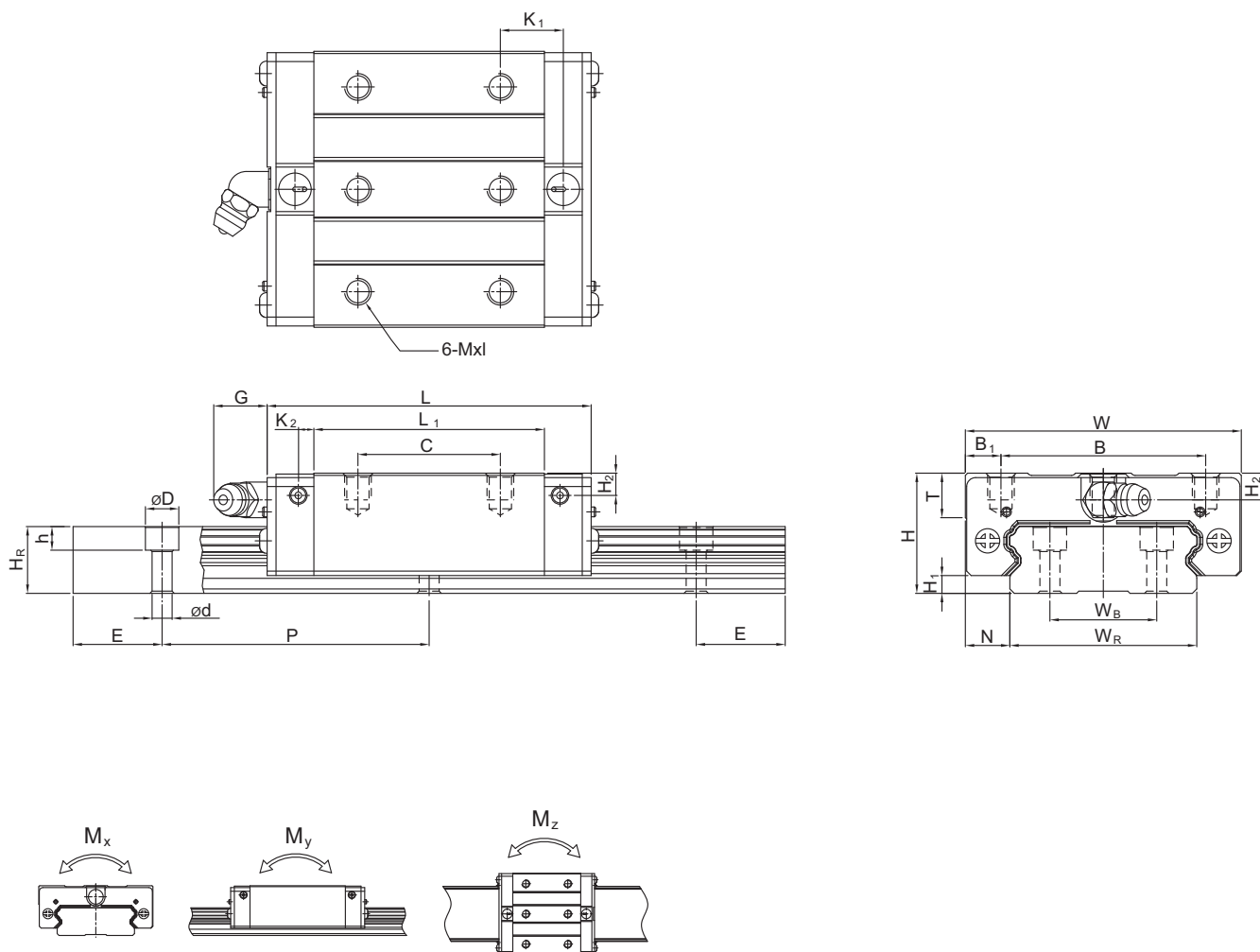

Označení	Rozměry [mm]																				Únosnost [N]		Moment [Nm]			Hmot. vozíku [kg]	Hmot. kolej. [kg/m]					
	Komplet		Vozík										Kolejnic								Mont. šroub	C _d	C ₀	M _x	M _y	M _z						
	H	H ₁	N	W	B	B ₁	C	L ₁	L	K ₁	K ₂	G	M × l	T	H ₂	H ₃	W _r	W _B	H _r	D								h	d	P	E	
WEH27CA	27	4	10	62	46	8	32	51,8	72,8	14,15	3,50	12	M6 × 6	10	6	5,0	42	24	15	7,5	5,3	4,5	60	*	M4 × 16	12400	21600	470	170	170	0,35	4,8
WEH35CA	35	4	15,5	100	76	12	50	77,6	104,6	18,10	5,25	12	M8 × 8	13	8	6,5	69	40	19	11	9,0	7,0	80	*	M6 × 20	29800	49400	1600	670	670	1,20	9,9

* Pokud zákazník neurčí jinak, oba konce E1 a E2 jsou symetrické. Při objednání prosíme o stanovení vzdálenosti prvního otvoru od začátku kolejnice. Formou E1 = .. mm.

Široké provedení – přírubové

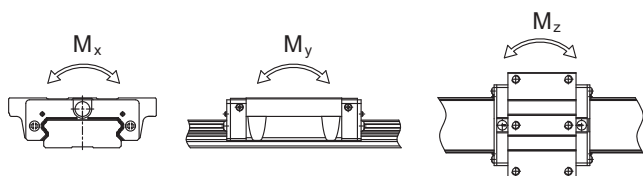
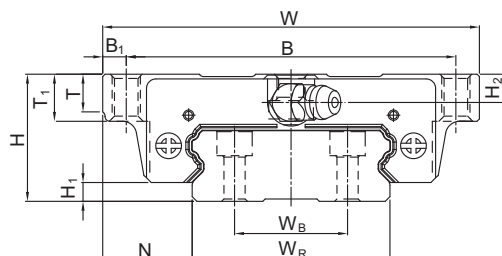
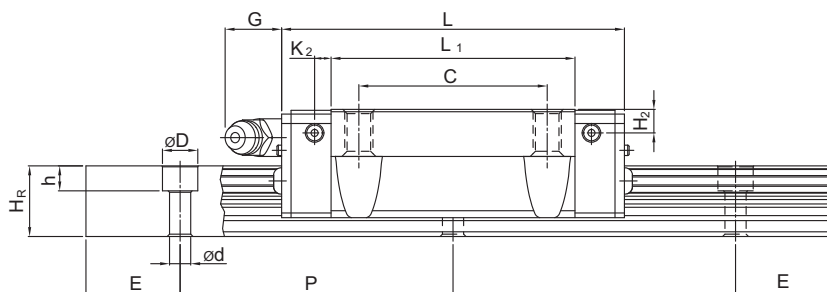
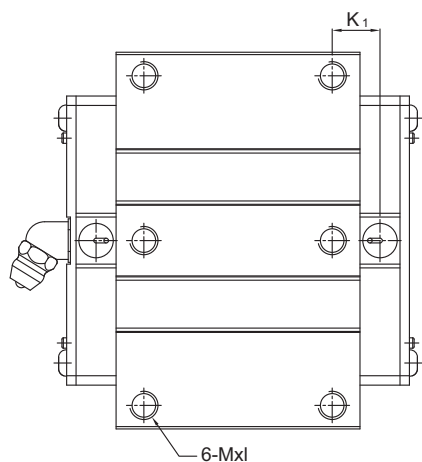

Označení	Rozměry [mm]																				Únosnost [N]			Moment [Nm]			Hmot. vozíku [kg]	Hmot. kolej. [kg/m]			
	Komplet				Vozík								Kolejnic								Mont. šroub	Cd	Co	Mx	My	Mz					
	H	H1	N	W	B	B1	C	L1	L	K1	K2	G	M × l	T	H2	WR	WB	HR	D	h									d	P	E
WEW27CC	27	4	19,0	80	70	5	40	51,8	72,8	14,15	3,50	12	M6	8,0	6	42	24	15	7,5	5,3	4,5	60	*	M4 × 16	12400	21600	470	170	170	0,50	4,8
WEW35CC	35	4	25,5	120	107	6,5	60	77,6	104,6	18,10	5,25	12	M8	11,2	8	69	40	19	11	9,0	7,0	80	*	M6 × 20	29800	49400	1600	670	670	1,35	9,9
WEW50CC	50	7,5	36	162	144	9	80	113,6	142	22,8	8,00	10	M10	12,0	9	90	60	32	15	11,5	9,0	80	*	M8 × 20	58200	86300	4270	920	1370	3,7	21

*Pokud zákazník neurčí jinak, oba konce E1 a E2 jsou symetrické. Při objednání prosíme o stanovení vzdálenosti prvního otvoru od začátku kolejnice. Formou E1 = . mm.

Úzké provedení

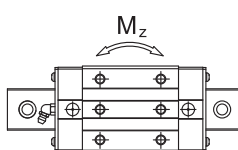
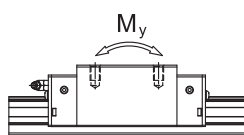
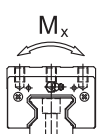
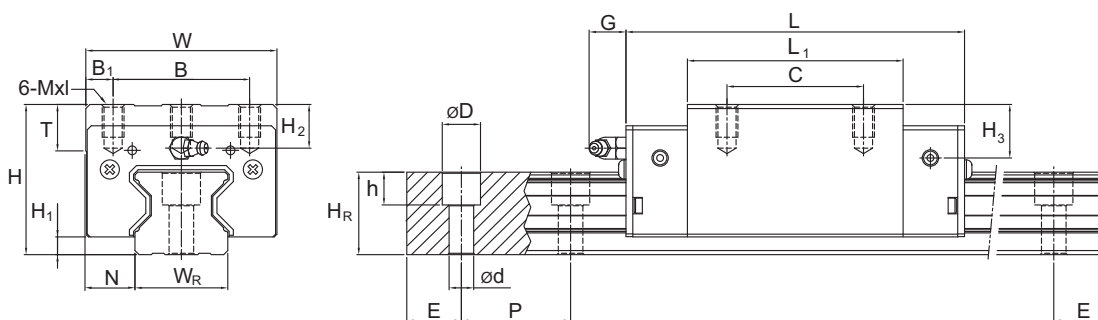
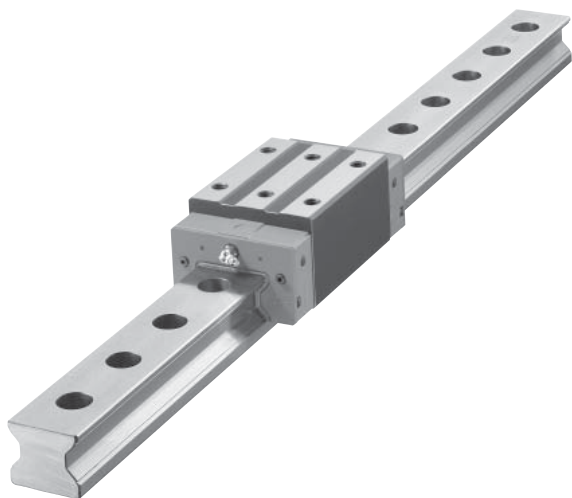

Označení	Rozměry [mm]																				Únosnost [N]		Moment [Nm]			Hmot. vozíku [g]	Hmot. kolej. [kg/m]		
	Komplet					Vozík					Kolejnic										Mont. šroub	Cd	Co	Mx	My			Mz	
	H	H1	N	W	B	B1	C	L1	L	G	M × l	T	H2	H3	WR	HR	D	h	d	P									E
RGH 25CA	40	5,5	12,5	48	35	6,5	35	64,5	97,9	12	M6 × 8	9,5	10,2	10	23	23,6	11	9	7	30	20	M6 × 20	27700	57100	758	605	605	0,55	3,08
RGH 25HA							50	81	114,4														33900	73400	975	991	991	0,7	
RGH 30CA	45	6	16	60	40	10	40	71	109,8	12	M8 × 10	9,5	9,5	13,8	28	28	14	12	9	40	20	M8 × 25	39100	82100	1445	1060	1060	0,82	4,41
RGH 30HA							60	93	131,8														48100	105000	1846	1712	1712	1,07	
RGH 35CA	55	6,5	18	70	50	10	50	79	124	12	M8 × 12	12	16	19,6	34	30,2	14	12	9	40	20	M8 × 25	57900	105200	2170	1440	1440	1,43	6,06
RGH 35HA							72	106,5	151,5														73100	142000	2930	2600	2600	1,86	
RGH 45CA	70	8	20,5	86	60	13	60	106	153,2	12,9	M10 × 17	16	20	24	45	38	20	17	14	52,5	22,5	M12 × 35	92600	178800	4520	3050	3050	2,97	9,97
RGH 45HA							80	139,8	187														116000	230900	6330	5470	5470	3,97	
RGH 55CA	80	10	23,5	100	75	12,5	75	125,5	183,7	12,9	M12 × 18	17,5	22	27,5	53	44	23	20	16	60	30	M14 × 45	130500	252000	8010	5400	5400	4,62	13,98
RGH 55HA							95	173,8	232														167800	348000	11150	10250	10250	6,4	
RGH 65CA	90	12	31,5	126	76	25	70	160	232	12,9	M16 × 20	25	15	15	63	53	26	22	18	75	35	M16 × 50	213000	411600	16200	11590	11590	8,33	20,22
RGH 65HA							120	223	295														275300	572700	22550	22170	22170	11,62	

* Pokud zákazník neurčí jinak, oba konce E1 a E2 jsou symetrické. Při objednání prosíme o stanovení vzdálenosti prvního otvoru od začátku kolejničky. Formou E1 = .. mm.

Přírubové provedení

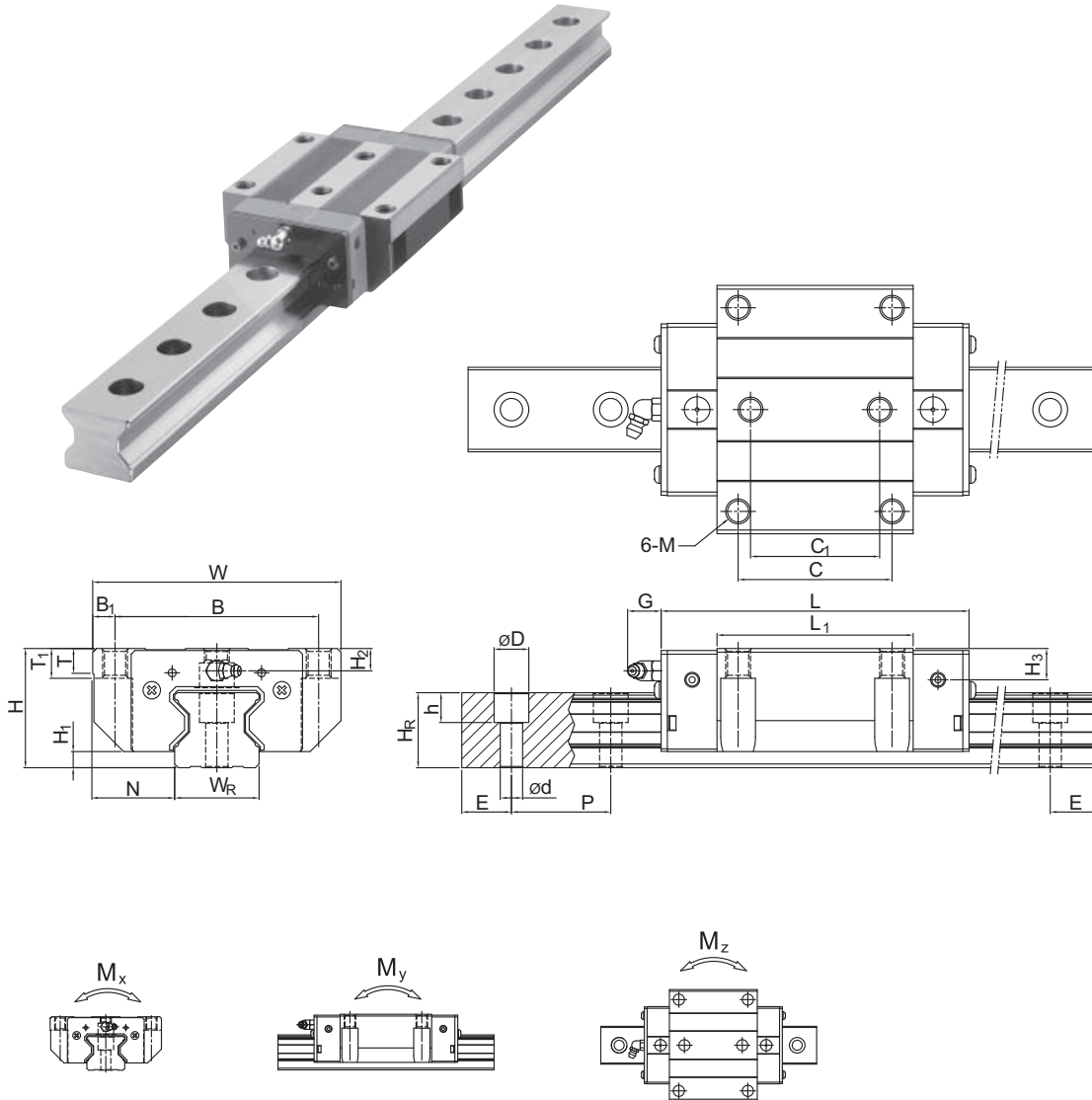

Označení	Rozměry [mm]																							Únosnost [N]		Moment [Nm]			Hmot. vozíku [g]	Hmot. kolej. [kg/m]	
	Komplet			Vozík										Kolejnic										Mont. šroub	Cd	Co	Mz	My			Mz
	H	H1	N	W	B	B1	C	C1	L1	L	G	M	T	T1	H2	H3	Wr	Hr	D	h	d	P	E								
RGW 25CC	36	5,5	23,5	70	57	6,5	45	40	64,5	97,9	12	M8	9,5	10	6,2	6	23	23,6	11	9	7	30	20	M6×20	27700	57100	758	605	605	0,67	3,8
RGW 25HC									81	114,4															33900	73400	975	991	991	0,86	
RGW 30CC	42	6	31	90	72	9	52	44	71	109,8	12	M10	9,5	10	6,5	10,8	28	28	14	12	9	40	20	M8×25	39100	82100	1445	1060	1060	1,06	4,41
RGW 30HC									93	131,8															48100	105000	1846	1712	1712	1,42	
RGW 35CC	48	6,5	33	100	82	9	62	52	79	124	12	M10	12	13	9	12,6	34	30,2	14	12	9	40	20	M8×25	57900	105200	2170	1440	1440	1,61	6,06
RGW 35HC									106,5	151,5															73100	142000	2930	2600	2600	2,21	
RGW 45CC	60	8	37,5	120	100	10	80	60	106	153,2	12,9	M12	14	15	10	14	45	38	20	17	14	52,5	22,5	M12×35	92600	178800	4520	3050	3050	3,22	9,97
RGW 45HC									139,8	187															116000	230900	6330	5470	5470	4,41	
RGW 55CC	70	10	43,5	140	116	12	95	70	125,5	183,7	12,9	M14	16	17	12	17,5	53	44	23	20	16	60	30	M14×45	130500	252000	8010	5400	5400	5,18	13,98
RGW 55HC									173,8	232															167800	348000	11150	10250	10250	7,34	
RGW 65CC	90	12	53,5	170	142	14	110	82	160	232	12,9	M16	22	23	15	15	63	53	26	22	18	75	35	M16×50	213000	411600	16200	11590	11590	11,04	20,22
RGW 65HC									223	295															275300	572700	22550	22170	22170	15,75	

*Pokud zákazník neurčí jinak, oba konce E1 a E2 jsou symetrické. Při objednání prosíme o stanovení vzdálenosti prvního otvoru od začátku kolejnice. Formou E1 = . mm.

Uchytení shora MGR..R, WER..R, HGR..R, EGR..U

MGNR, HGR, EGR

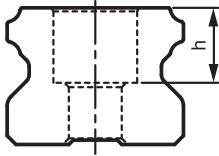

MGWR, WER

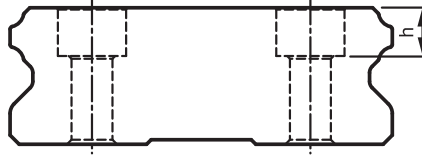

Rozměry kolejnice [mm]	Typ kolejnice									
	MGNR7R	MGNR9R	MGNR12R	MGNR15R	MGWR7R	MGWR9R	MGWR12R	MGWR15R	WER27R	WER35R
h	2,3	3,5	4,5	4,5	3,2	4,5	4,5	4,5	5,3	9

Rozměry kolejnice [mm]	8.5Typ kolejnice									
	HGR15R	HGR20R	HGR25R	HGR30R	HGR35R	HGR45R	HGR55R	HGR65R	EGR15U	EGR30U
h	5,3	8,5	9	12	12	17	20	22	5,3	12

Uchytení ze spodu HGR..T, EGR..T, RGR..T

HGR, EGR

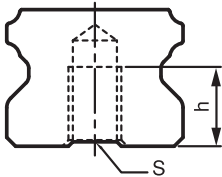

RGR

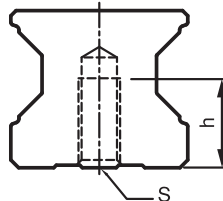

Rozměry kolejnice [mm]	Typ kolejnice											
	HGR15T	HGR20T	HGR25T	HGR30T	HGR35T	HGR45T	HGR55T	HGR65T	EGR15T	EGR20T	EGR25T	EGR30T
S	M5	M6	M6	M8	M8	M12	M14	M20	M5	M6	M6	M8
h	8	10	12	15	17	24	24	30	7	9	10	14

Rozměry kolejnice [mm]	Typ kolejnice								
	RGR15T	RGR20T	RGR25T	RGR30T	RGR35T	RGR45T	RGR55T	RGR65T	
S	M5	M6	M6	M8	M8	M12	M14	M20	
h	8	10	12	15	17	24	24	30	

* Pokud zákazník neurčí jinak, oba konce E1 a E2 jsou symetrické. Při objednání prosíme o stanovení vzdálenosti prvního otvoru od začátku kolejnice. Formou E1 = .. mm.

Lineární moduly

GD6M

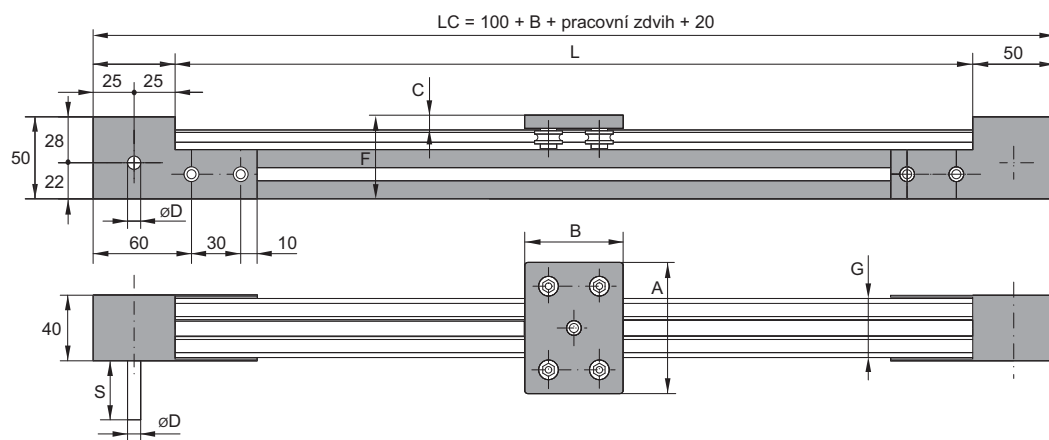
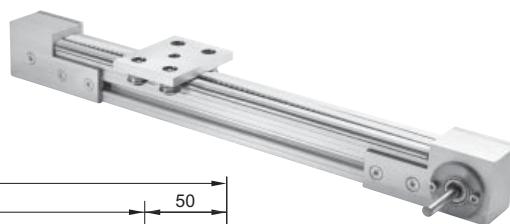

GD10..M, GD20..M

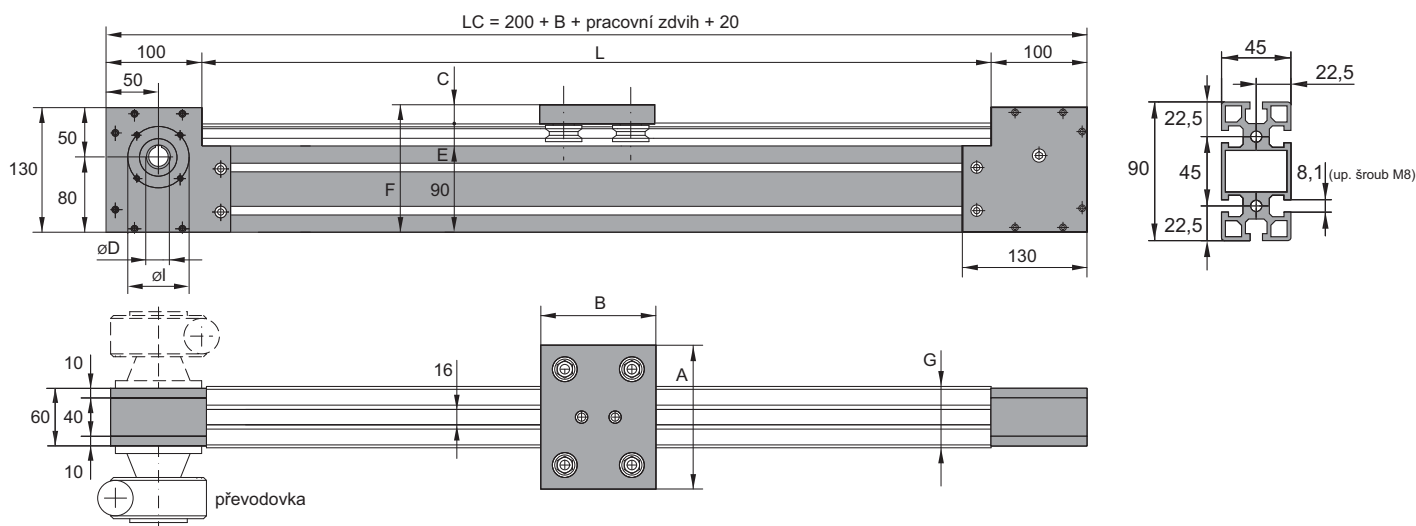

Označení	Rozměry [mm]							Řemen	Max. síla na řemeni [N]	Limitní síla na řemeni [N]	Hnací řemenice	1 otáčka hnacího hřídele [mm]	Rozsah vypnutí řemene [mm]
	A	B	C	øD	E	F	G						
GD6M	80	60	8	8 ^{h7}		51	36	AT5/10	630	1960	AT5-10-22	110	5
GD10AM	120	80	10	14-19 ^{H7}	21	121	64	AT10/16	2190	7480	AT10-16-20	200	14
								AT10/25	3600	12400	AT10-25-20		
GD10BM	140	120	15	14-19 ^{H7}	22	127	64	AT10/16	2190	7480	AT10-16-20	200	14
								AT10/25	3600	12400	AT10-25-20		
GD10CM	150	120	20	14-19 ^{H7}	24	134	64	AT10/16	2190	7480	AT10-16-20	200	14
								AT10/25	3600	12400	AT10-25-20		
GD20AM	180	150	20	14-19 ^{H7}	31	141	90	AT10/16	2190	7480	AT10-16-20	200	14
								AT10/25	3600	12400	AT10-25-20		
GD20BM	200	180	25	14-19 ^{H7}	36,5	151,5	90	AT10/16	2190	7480	AT10-16-20	200	14
								AT10/25	3600	12400	AT10-25-20		

Typ převodovky (pro moduly GD10, GD20)	Výrobce	Průměr øl	Počet otvorů	Závít	Poloha
RMI-28FL	STM	62	4	M5	90°
RMI-40F1	STM	87	4	M8	90°

GD10MLT, GD20MLT

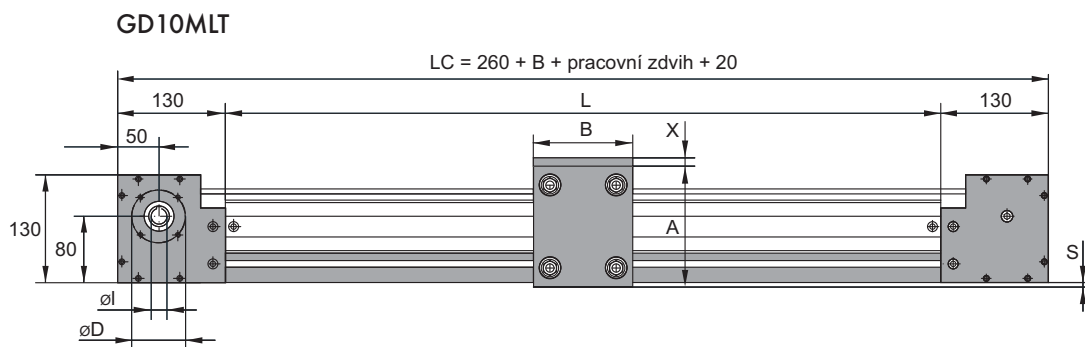

GD20MLT

$LC = 260 + B + \text{pracovní zdvih} + 20$

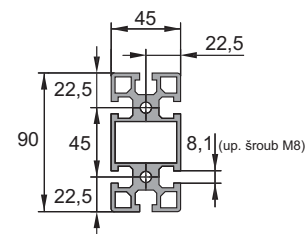
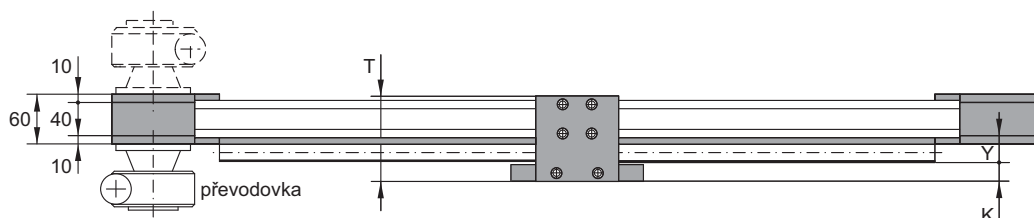
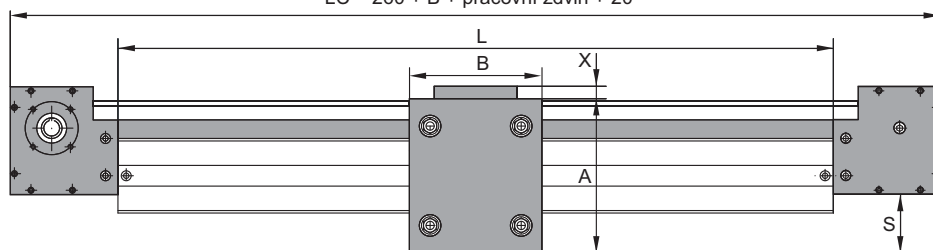

Označení	Rozměry [mm]								Řemen	Max. síla na řemeni [N]	Limitní síla na řemeni [N]	Hnací řemenice	1 otáčka hnacího hřídele [mm]	Rozsah vypnutí řemene [mm]
	A	B	øD ^{H7}	K	S	T	X	Y						
GD10AMLT	120	80	14-19	11		80	10	12,5	AT10/16	2190	7480	AT10-16-20	200	14
									AT10/25	3600	12400	AT10-25-20		
GD10BMLT	140	120	14-19	17	2,5	85	10	12,5	AT10/16	2190	7480	AT10-16-20	200	14
									AT10/25	3600	12400	AT10-25-20		
GD10CMLT	150	120	14-19	24	7,5	92	15	12,5	AT10/16	2190	7480	AT10-16-20	200	14
									AT10/25	3600	12400	AT10-25-20		
GD20AMLT	180	150	14-19	21	67,5	100	15	22,5	AT10/16	2190	7480	AT10-16-20	200	14
									AT10/25	3600	12400	AT10-25-20		
GD20BMLT	200	180	14-19	31,5	77,5	110	14	22,5	AT10/16	2190	7480	AT10-16-20	200	14
									AT10/25	3600	12400	AT10-25-20		

Typ převodovky (pro moduly GD10, GD20)	Výrobce	Průměr øl	Počet otvorů	Závít	Poloha
RMI-28FL	STM	57	4	M5	90°
RMI-40F1	STM	87	4	M8	90°

ILM32: LC = 100 + 120 + pracovní zdvih + 20
 ILM42: LC = 160 + 180 + pracovní zdvih + 20

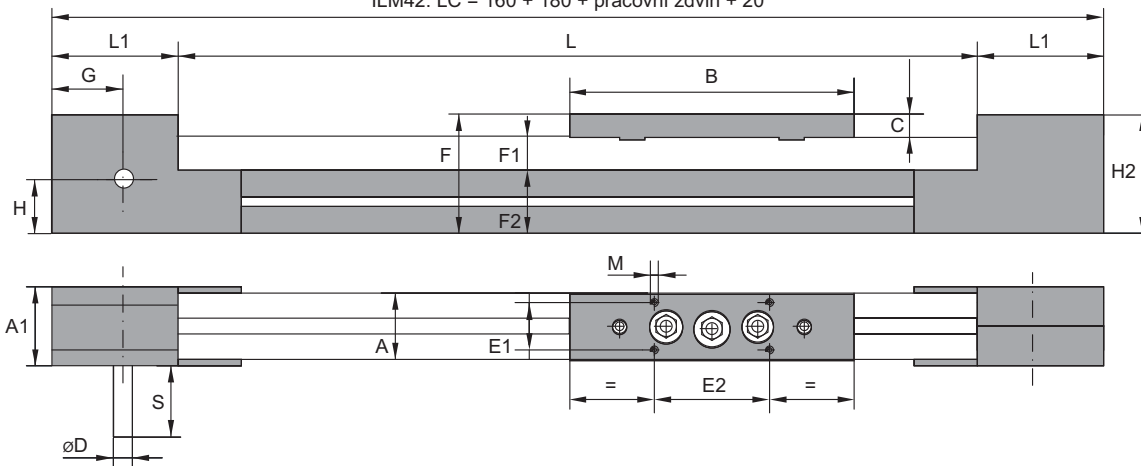

ILM65: LC = 200 + 210 + pracovní zdvih + 20

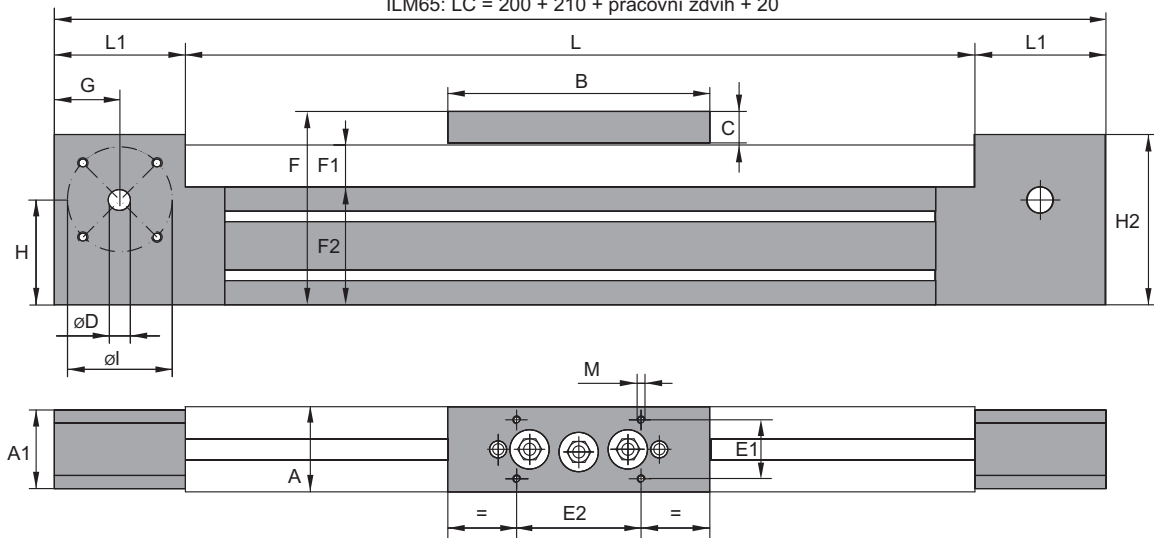

Označ.	Rozměry [mm]														Řemen	Max. síla na řemeni [N]	Limitní síla na řemeni [N]	Hnací řemnice	1 otáčka hnacího hřídele [mm]	Rozsah vypnutí řemene [mm]		
	A	A1	B	C	øD	E1	E2	F	F1	F2	G	H	H2	L1							M	S
ILM32	32	40	120	11	8 ^{h7}	20	57	58,5			25	22	50	50	M4	40	AT5/10	630	1960	AT5-10-22	110	5
ILM42	42	50	180	14	12 ^{h7}	30	73	75,5	20	40	45	34	75	80	M5	50	AT5/10	630	1960	AT5-10-32	160	5
ILM65	65	60	210	24	14-19 ^{H7}	45	95	147,6	32	90	50	80	130	100	M6		AT10/16	2190	7480	AT10-16-20	200	14

Typ převodovky (pro moduly ILM65)	Výrobce	Průměr øl	Počet otvorů	Závit	Poloha
RMI-28FL	STM	56	4	M5	90°
RMI-40F1	STM	87	4	M8	90°

Označení	Max. zatížení [N]		Statický moment [Nm]			Komponenty	
	F _a	F _r	M _x	M _y	M _z	Rolny	Vozík
ILM32	330	980	3,2	5,2	9	RPE17 + RPC17	C32
ILM42	500	1680	7,5	14,5	25	RPE24 + RPC24	C42
ILM65	1160	3930	25,5	44	76	RPE35 + RPC35	C65

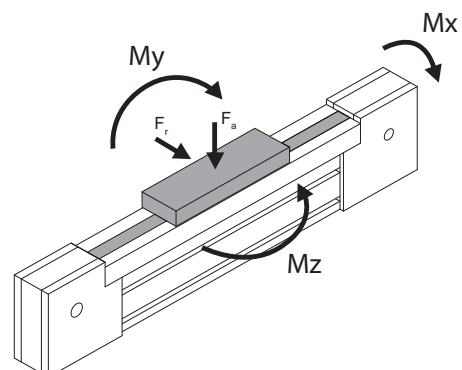

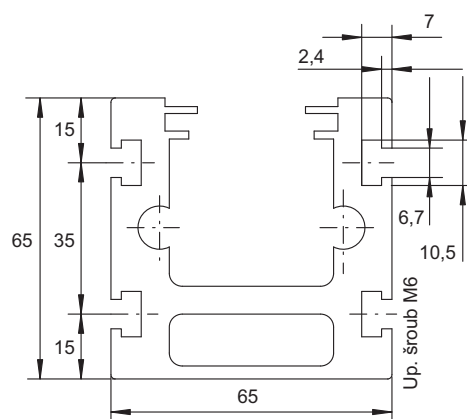
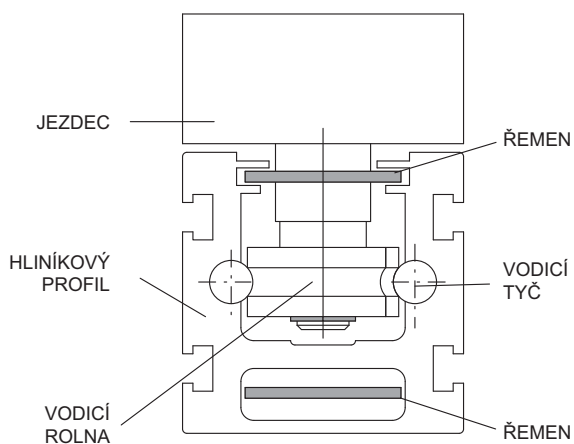
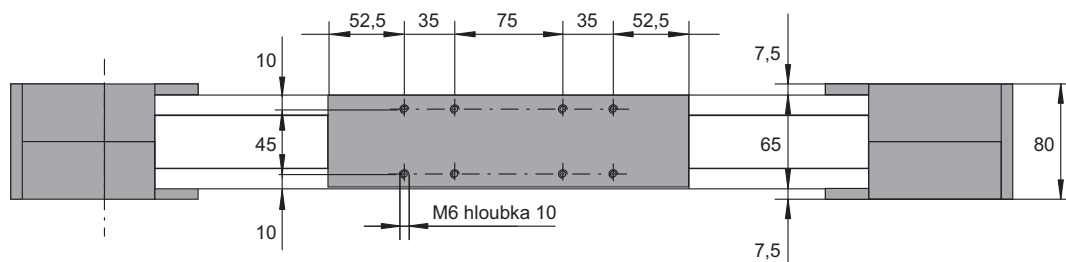
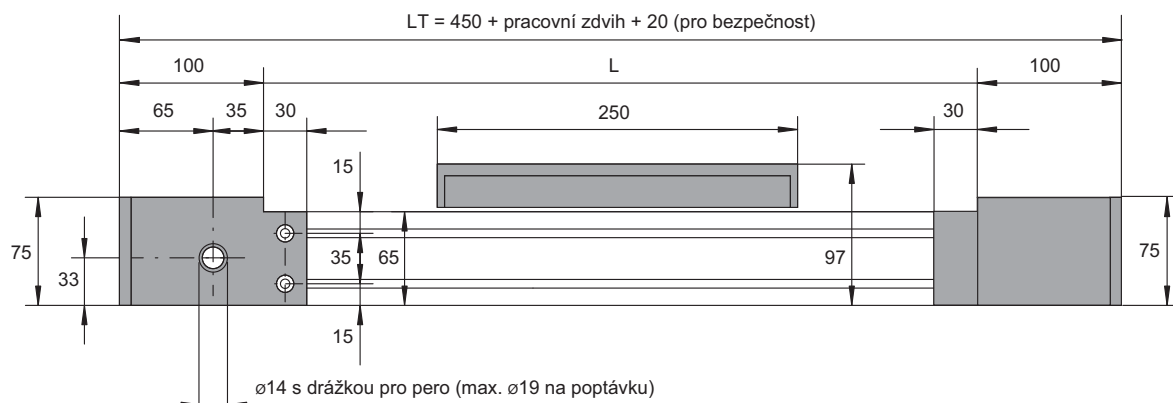

Označení	Pracovní zdvih min. [mm]	Pracovní zdvih max. [mm]	Max. rychlost [m/s]	Hnací řemen	Hnací řemenice	1 ot. hnací hřídele [mm]	Hmotnost jezdce [kg]	Základní hmotnost [kg]	Hmotnost na 100 mm zdvihu [kg]
TLM65R	105	5730	2,5	AT5 × 36	AT5-36-34	170	1,1	3,4	0,6

Označení	Zatížení [N]		Statický momenty [Nm]			Dynamický momenty [Nm]		
	Stat.	Dynam.	M_x	M_y	M_z	M_x	M_y	M_z
TLM65R	635	530	16	26	42	13	24	42

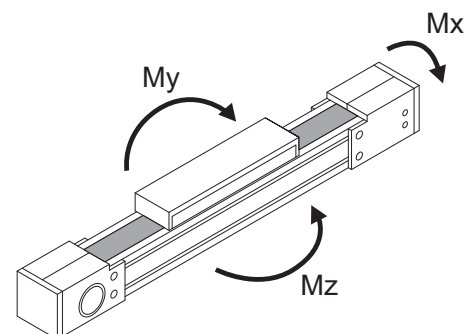

TLM65G Lineární modul s kolejnicovým vedením a řemenem

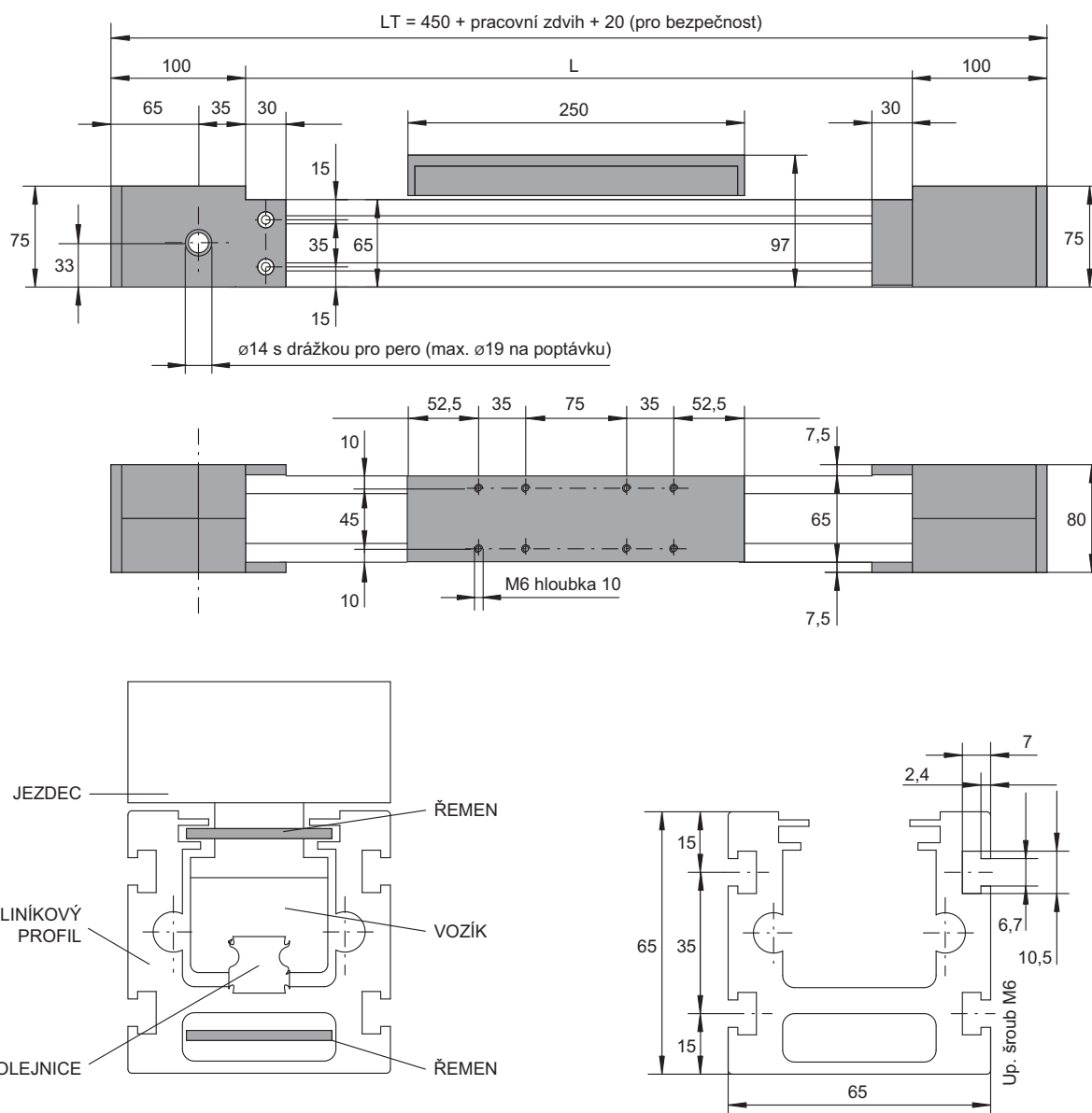

Označení	Pracovní zdvih min. [mm]	Pracovní zdvih max. [mm]	Max. rychlost [m/s]	Hnací řemen	Hnací řemenice	1 ot. hnací hřídele [mm]	Hmotnost jezdce [kg]	Základní hmotnost [kg]	Hmotnost na 100 mm zdvihu [kg]
TLM65G	105	5730	4,5	AT5 × 36	AT5-36-34	170	1,2	3,6	0,7

Označení	Zatížení [N]		Statický momenty [Nm]			Dynamický momenty [Nm]		
	Stat.	Dynam.	M_x	M_y	M_z	M_x	M_y	M_z
TLM65G	16500	3400	68	445	380	15	92	82

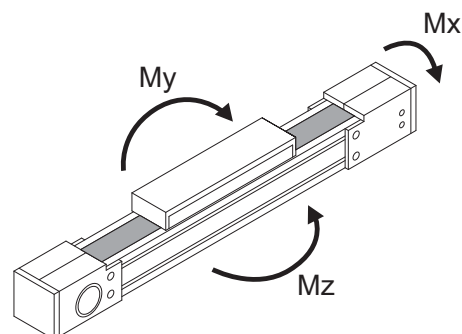

Lineární modul s kolej. vedením a kuličkovým šroubem TLM65V

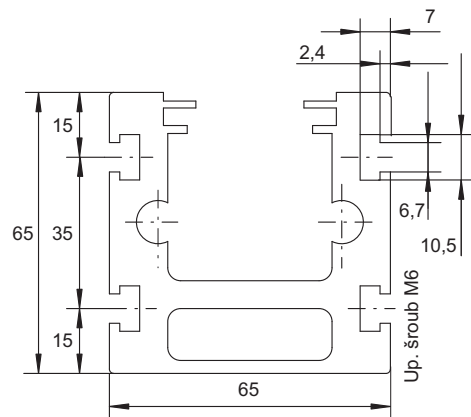
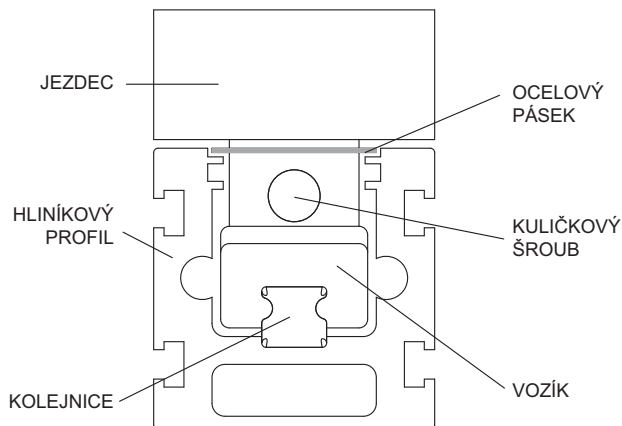
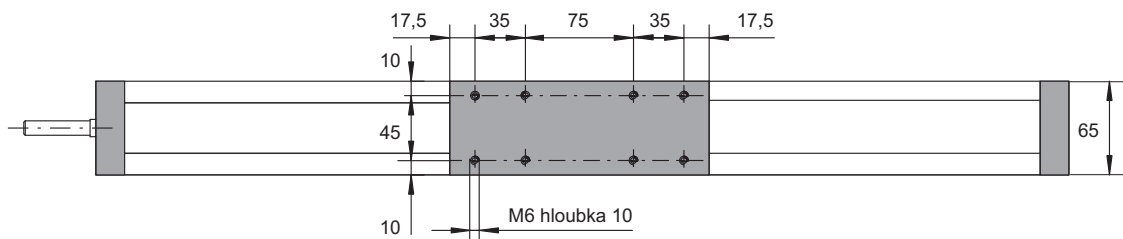
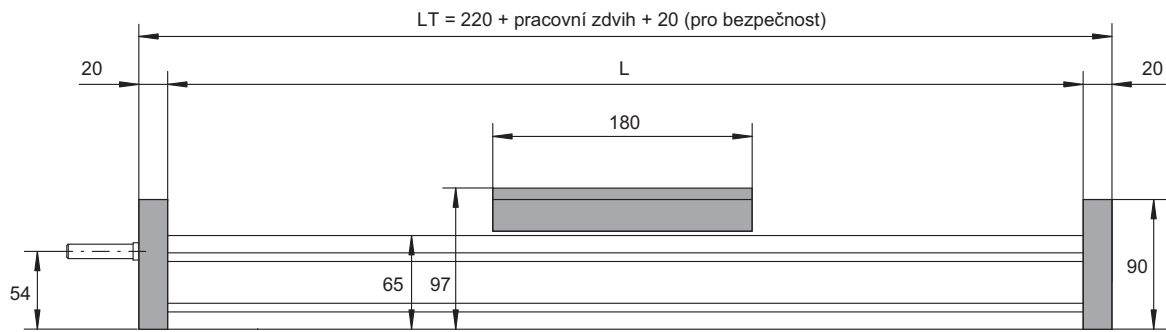

Označení	Pracovní zdvih min. [mm]	Pracovní zdvih max. [mm]	Max. rychlost [m/s]	Kuličkový šroub (standard)	Hmotnost jezdce [kg]	Základní hmotnost [kg]	Hmotnost na 100 mm zdvihu [kg]
TLM65V	105	2000		16 × 5	1,2	2,8	0,9

Označení	Zatížení [N]		Statický momenty [Nm]			Dynamický momenty [Nm]		
	Stat.	Dynam.	M_x	M_y	M_z	M_x	M_y	M_z
TLM65V	16500	3400	68	445	380	15	92	82

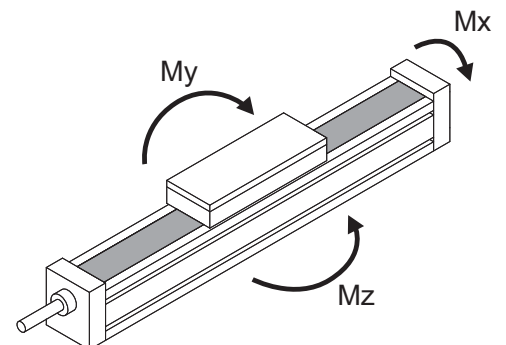

TLM80R Lineární modul s rolničkovým vedením a řemenem

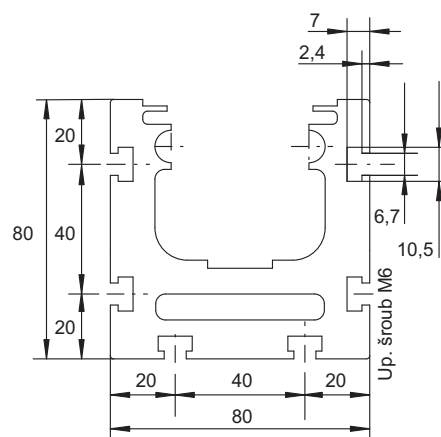
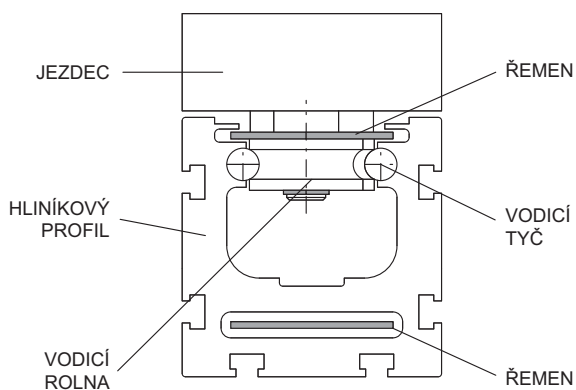
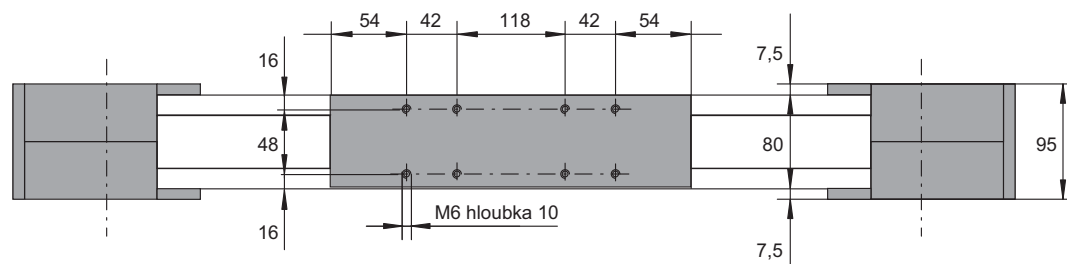
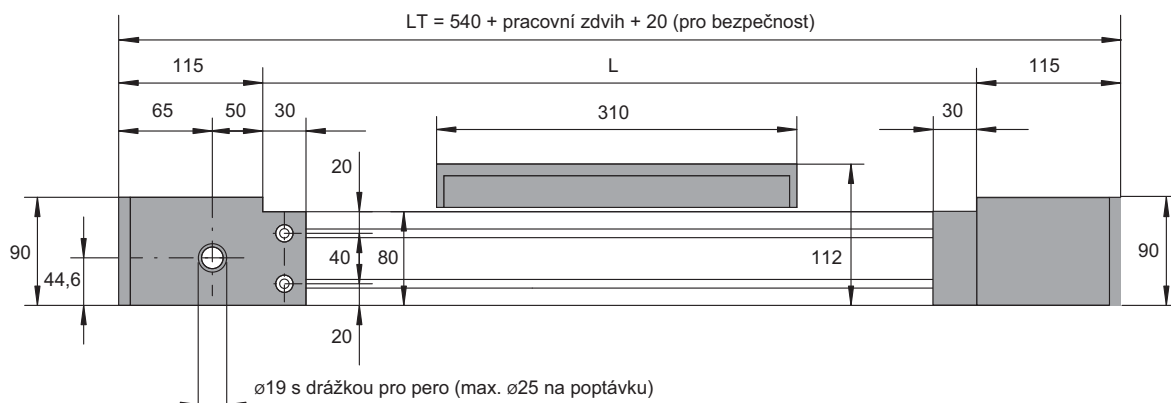

Označení	Pracovní zdvih min. [mm]	Pracovní zdvih max. [mm]	Max. rychlost [m/s]	Hnací řemen	Hnací řemenice	1 ot. hnací hřídele [mm]	Hmotnost jezdce [kg]	Základní hmotnost [kg]	Hmotnost na 100 mm zdvihu [kg]
TLM80R	105	5670	2,5	AT5 × 50	AT5-50-37	185	2,4	6,2	1,1

Označení	Zatížení [N]		Statický momenty [Nm]			Dynamický momenty [Nm]		
	Stat.	Dynam.	M_x	M_y	M_z	M_x	M_y	M_z
TLM80R	635	530	32	52	84	26	48	84

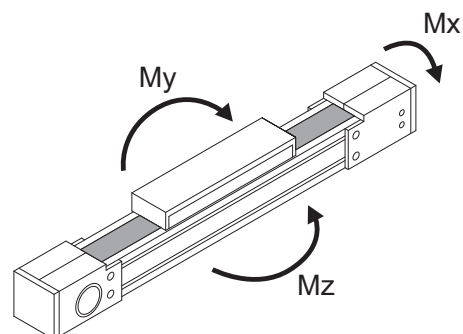

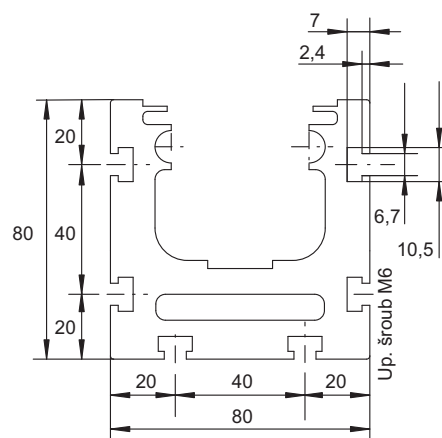
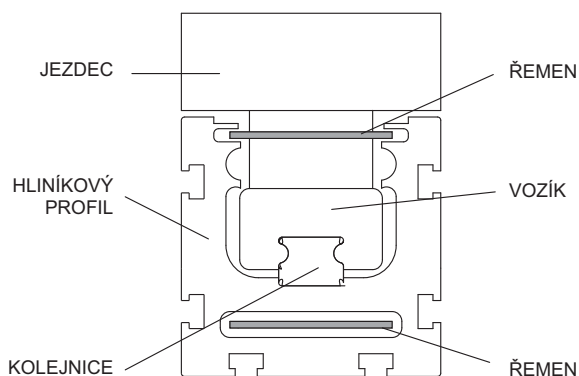
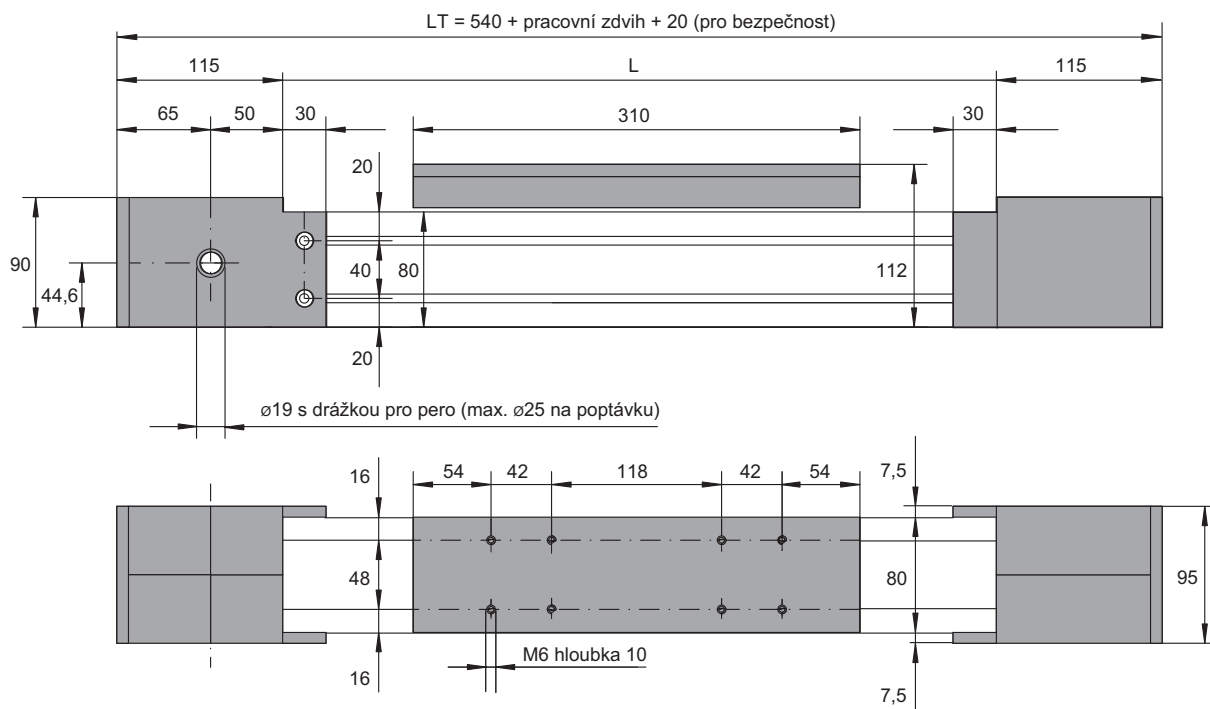

Označení	Pracovní zdvih min. [mm]	Pracovní zdvih max. [mm]	Max. rychlost [m/s]	Hnací řemen	Hnací řemenice	l ot. hnací hřídele [mm]	Hmotnost jezdce [kg]	Základní hmotnost [kg]	Hmotnost na 100 mm zdvihu [kg]
TLM80G	105	5670	4,5	AT5 × 50	AT5-50-37	185	2,5	6,4	1,3

Označení	Zatížení [N]		Statický momenty [Nm]			Dynamický momenty [Nm]		
	Stat.	Dynam.	M _x	M _y	M _z	M _x	M _y	M _z
TLM80G	23400	4600	118	860	740	25	178	160

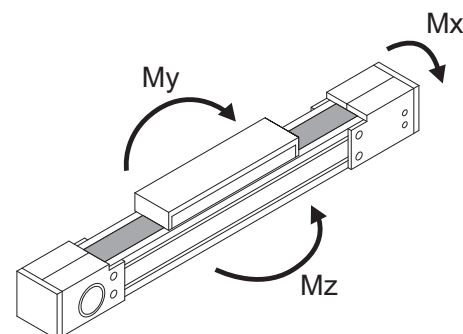

TLM80V Lineární modul s kolej. vedením a kuličkovým šroubem

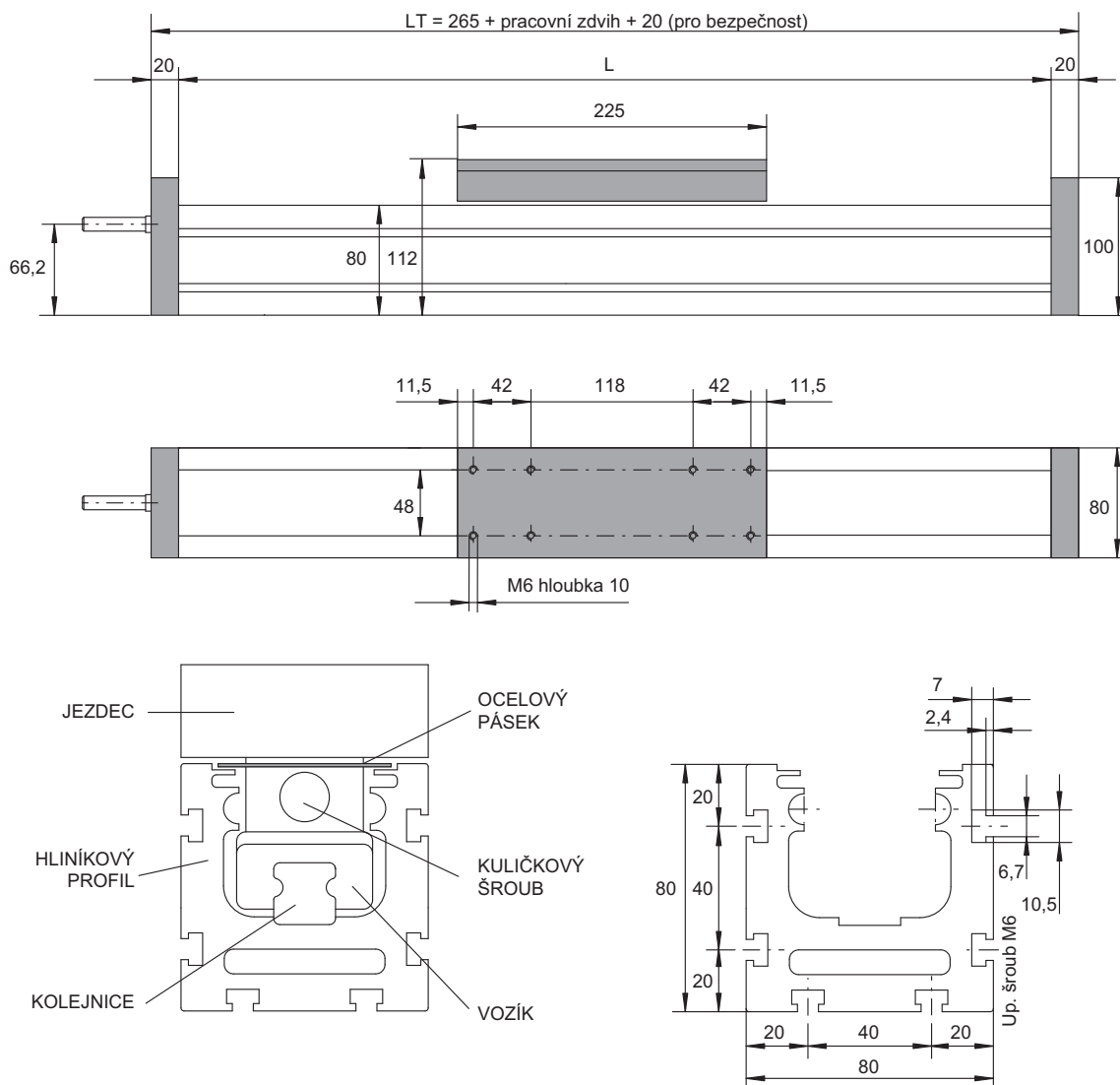

Označení	Pracovní zdvih min. [mm]	Pracovní zdvih max. [mm]	Max. rychlost [m/s]	Kuličkový šroub (standard)	Hmotnost jezdce [kg]	Základní hmotnost [kg]	Hmotnost na 100 mm zdvihu [kg]
TLM80V	105	2000		16 × 5	2,5	3,6	1,4

Označení	Zatížení [N]		Statický momenty [Nm]			Dynamický momenty [Nm]		
	Stat.	Dynam.	M_x	M_y	M_z	M_x	M_y	M_z
TLM80V	19000	4000	118	550	500	25	120	115

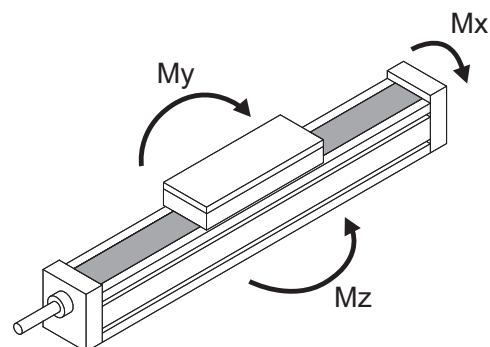

Lineární modul s kolejnicovým vedením a řemenem **TLM105G**

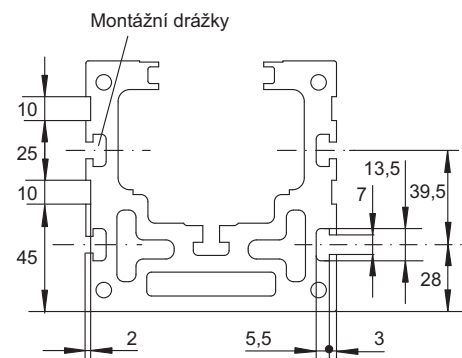
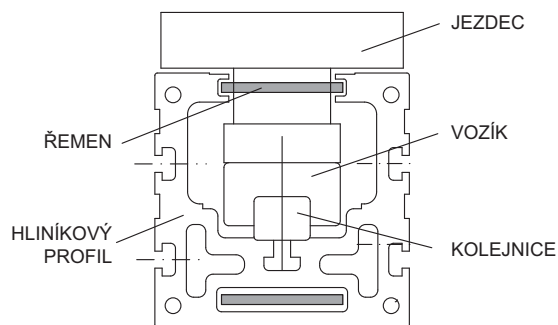
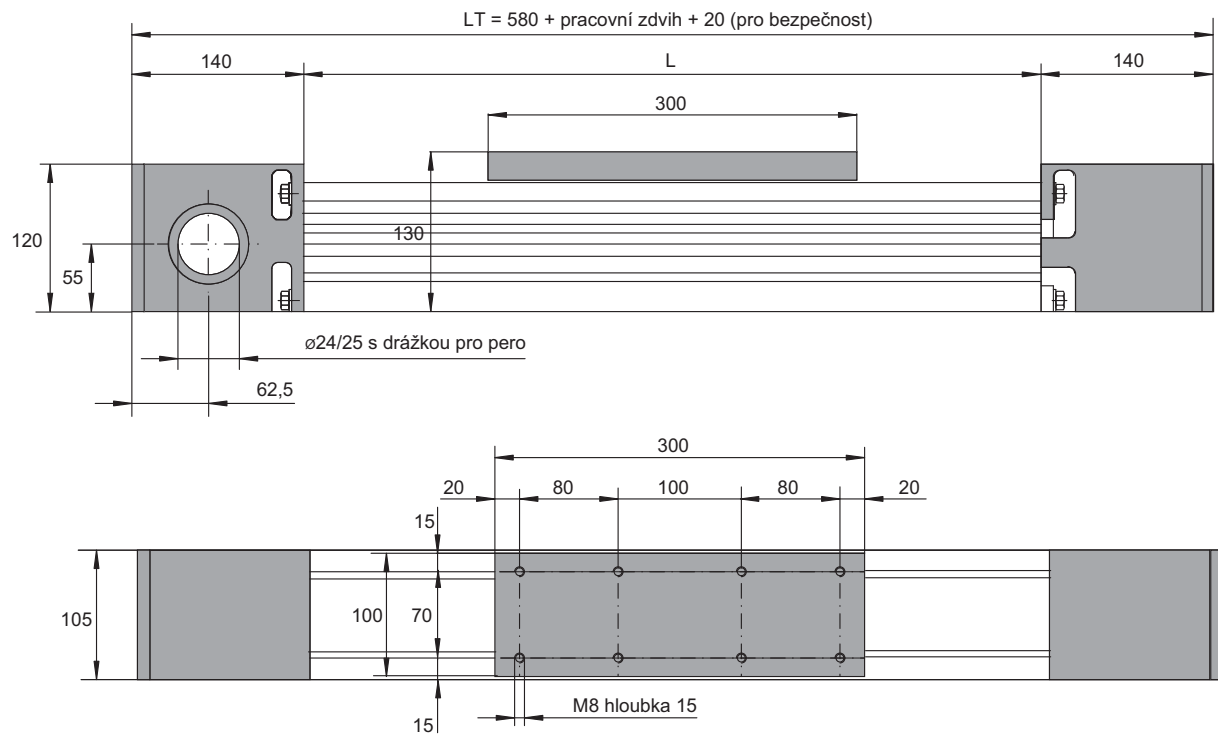

Označení	Pracovní zdvih min. [mm]	Pracovní zdvih max. [mm]	Max. rychlost [m/s]	Hnací řemen	Hnací řemenice	1 ot. hnací hřídele [mm]	Hmotnost jezdce [kg]	Základní hmotnost [kg]	Hmotnost na 100 mm zdvihu [kg]
TLM105G	105	7950	5	AT10 × 50	AT10-50-28	280	5,8	12,6	1,8

Označení	Zatížení [N]		Statický momenty [Nm]			Dynamický momenty [Nm]		
	Stat.	Dynam.	M_x	M_y	M_z	M_x	M_y	M_z
TLM105G	36400	7400	201	1475	1283	42	313	273

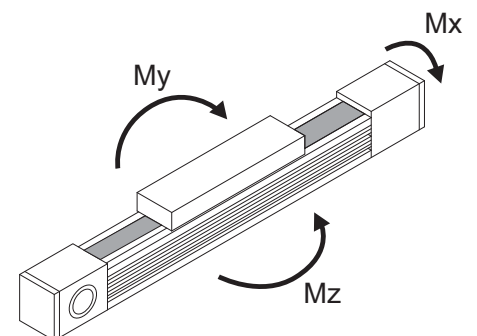

TLM105V Lineární modul s kolej. vedením a kuličkovým šroubem

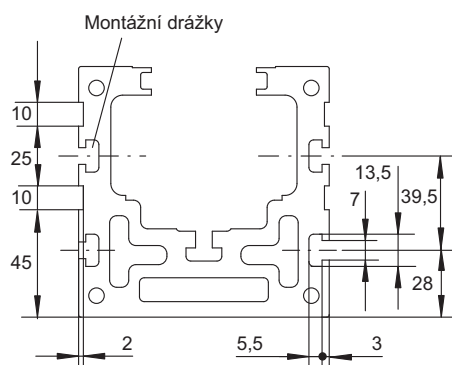
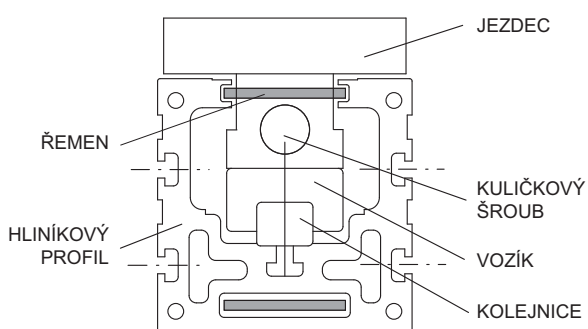
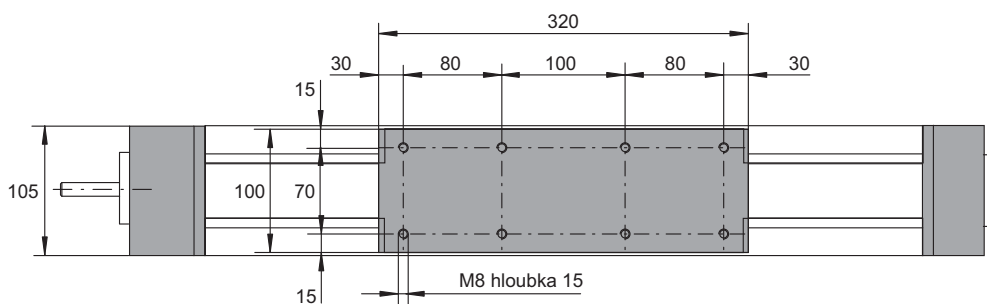
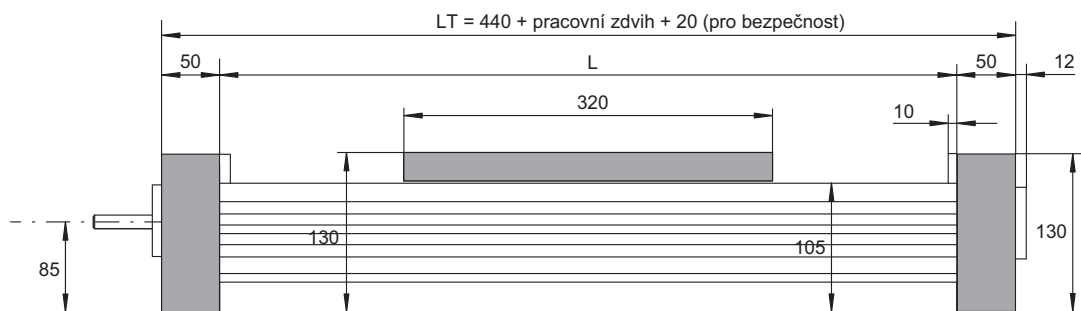

Označení	Pracovní zdvih min. [mm]	Pracovní zdvih max. [mm]	Max. rychlost [m/s]	Kuličkový šroub (standard)	Hmotnost jezdce [kg]	Základní hmotnost [kg]	Hmotnost na 100 mm zdvihu [kg]
TLM105V	105	3500		25 × 5	3,8	4,8	1,9

Označení	Zatížení [N]		Statický momenty [Nm]			Dynamický momenty [Nm]		
	Stat.	Dynam.	M_x	M_y	M_z	M_x	M_y	M_z
TLM105V	36400	7400	201	1475	1283	42	313	273

Objednací číslo:

TLM 105 V 400
 | typ | velikost | proveden | zdvih

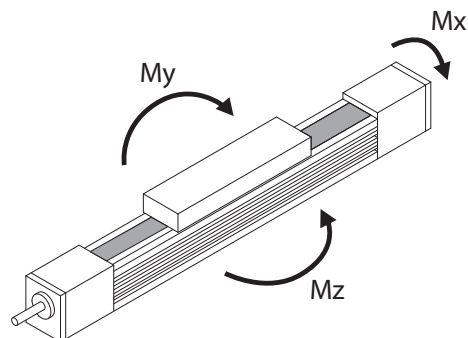

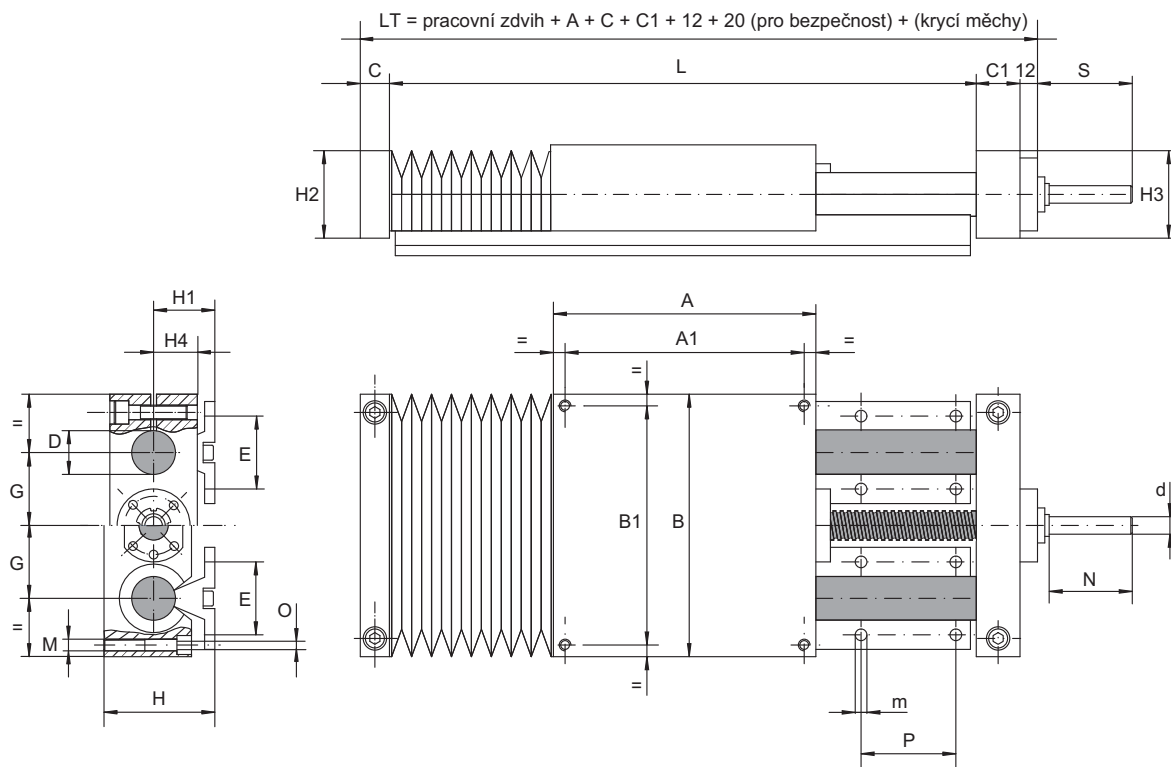

Označení	Rozměry [mm]																				
	A	A1	B	B1	C	C1	D	d	E	G	H	H1	H2	H3	H4	M	m	N	O	P	S
SLTL16-124	100	88	100	88	18	24	16	5	33	27	48	26	32	32	16	M6	5,5	12	5,3	100	16,5
SLTL20-165	130	115	130	115	20	29	20	9	37	36	57	32	42	42	21	M8	6,6	18	6,7	100	25,0
SLTL25-165	160	140	160	140	25	33	25	9	42	44	66	36	52	52	26	M10	6,6	18	8,5	120	22,5
SLTL30-205	180	158	180	158	25	38	30	10	51	48	77	42	58	58	29	M12	9,0	18	10,3	150	24,5

Označení	Kuličkový šroub		Zatížení [N]								Statické momenty [Nm]		
	Stoupání	Matice	Zatížení [N]		F1		F2		F3		M _x	M _y	M _z
			C _o	C _d	Dynam.	Stat.	Dynam.	Stat.	Dynam.	Stat.			
SLTL16-124	12 × 4	RSB12-04B1	5740	3440	1800	2450	820	980	1500	2100	28	34	68
SLTL20-165	16 × 5	FSI16-05T3	12270	6790	3600	5000	2000	2800	3680	5220	104	125	223
SLTL25-165	16 × 5	FSI16-05T3	12270	6790	6585	9260	3670	5135	6585	9260	230	265	480
SLTL30-205	20 × 5	FSI20-05T4	21490	10010	8340	12160	4600	6650	8340	12160	320	378	675

Objednávací číslo:

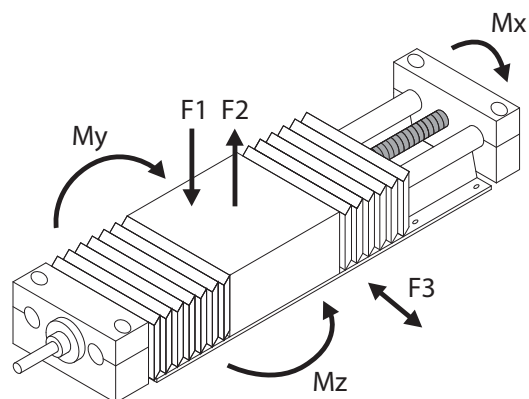
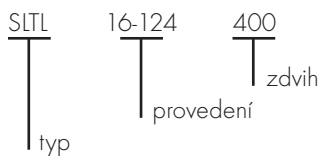

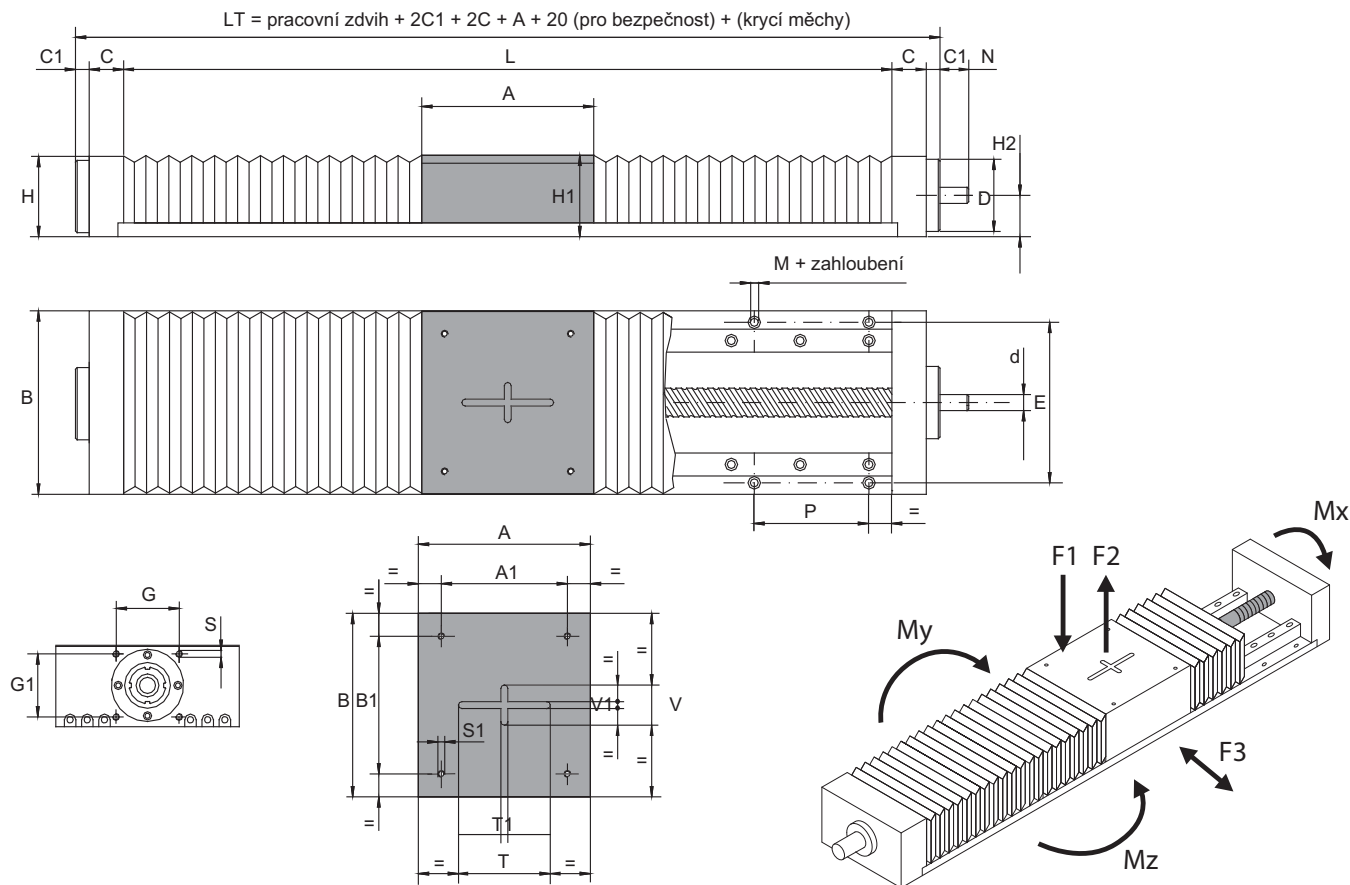

Označení	Rozměry [mm]																						
	A	A1	B	B1	C	C1	D	d	E	G	G1	H	H1	H2	M	N	P	S	S1	T	T1	V	V1
SLTL15-G	120	100	125	105	25	8	60h7	10h7	110	55	55	60	60	30	6,5	25	80	M6	M2	60	5	25	5
SLTL20-G	150	130	160	140	30	12	60h7	14h7	140	55	55	70	71	36	6,5	25	80	M6	M6	80	6	35	6
SLTL25-G	180	160	180	160	30	12	60h7	14h7	160	55	55	80	85	40	6,5	40	100	M6	M8	100	6	50	6

Označení	Kuličkový šroub			Zatížení [N]						Statické momenty [Nm]					
	Průměr	Stoupání		F1		F2		F3		M _x		M _y		M _z	
		Stat.	Dynam.	Stat.	Dynam.	Stat.	Dynam.	Stat.	Dynam.	Stat.	Dynam.	Stat.	Dynam.	Stat.	Dynam.
SLTL15-G-S	16	5	10	12500	5600	3100	1400	2091	970	500	190	150	90	130	60
SLTL15-G-H				18000	8400	4500	2100	2091	970	620	270	150	90	130	60
SLTL20-G-S	20	5	10	20400	10500	6100	2600	3196	1360	1310	560	470	290	400	200
SLTL20-G-H				36600	15800	9100	3900	3760	1600	1850	750	470	290	400	200
SLTL25-G-S	25	5	10	38000	16300	9500	4000	5400	1880	2000	800	880	490	700	305
SLTL25-G-H				57000	24400	14200	6100	5400	1880	2700	1100	880	490	700	305

Objednací číslo:

SLTL	15G	5	400	S	
↓	↓	↓	↓	↓	↓
typ	velikost	stoupání kuličkového šroubu (5, 10)	zdvih	provedení (S - standard, H - vysoké zatížení)	

Přesnost KK modulů

Označení	Délka pojezdové dráhy [mm]	Opakovaná přesnost [mm]		Přesnost [mm]		Rovnoběžnost vedení [mm]		Rozběhový moment [Nmm]	
		P*	C**	P*	C**	P*	C**	P*	C**
KK40	100	±0,003		0,020		0,010		12	
	150								
	200								
KK50	150	±0,003		0,020		0,010		40	
	200								
	250								
	300								
KK60	150	±0,003	±0,01	0,020		0,010		150	70
	200								
	300								
	400								
	500								
KK86	340	±0,003	±0,01	0,025		0,015		150	100
	440								
	540								
	640			0,030		0,020		170	
	740			0,040		0,030		250	
	940								
KK100	980	±0,005	±0,01	0,035		0,025		170	120
	1080			0,040		0,030		200	
	1180			0,045		0,040		230	
	1280			0,050		0,040		250	
	1380								

* Přesný KK modul.
 ** Normální KK modul.

Objednávací číslo:

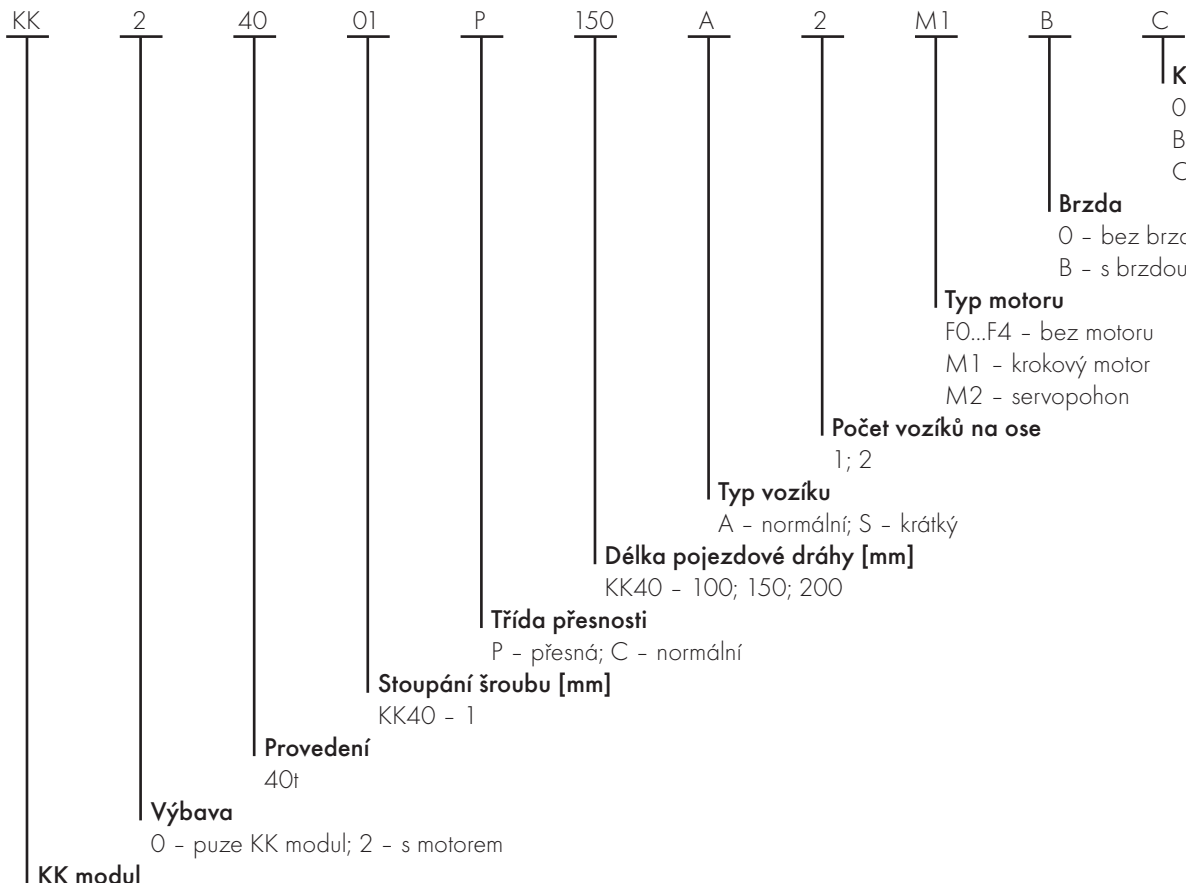

KK40 Lineární modul s kolej. vedením a kuličkovým šroubem

Modul bez krytování, standardní vozík

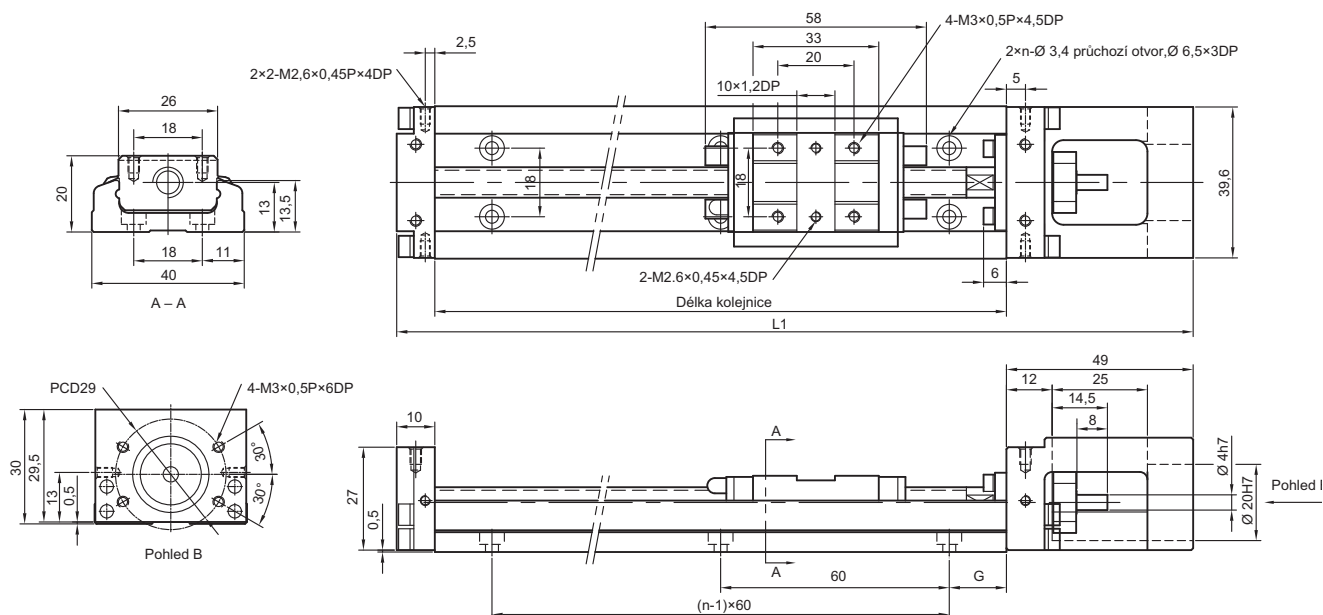

Rozměry [mm]											Hmotnost [kg]		
Délka pojezd. dráhy	Celková délka L1	Maximální zdvih		G	n	Kuličkový šroub				Rychlost [mm/s]		Vozík A1	Vozík A2
		Vozík A1	Vozík A2			Jmenovitý průměr	Stoupání	Dynamická únosnost [N]	Statická únosnost [N]	Přesné	Normální		
100	159	36		20	2	8	1	735	1538	190		0,48	
150	209	86	34	15	3	8	1	735	1538	190		0,60	0,67
200	259	136	84	40	3	8	1	735	1538	190		0,72	0,79

Lineární vedení							
Únosnost [N]		Dovolený statický moment [Nm]					
Dynamická	Statická	M_x		M_y		M_z	
Standardní vozík A	Standardní vozík A	Standardní vozík A1	Standardní vozík A2	Standardní vozík A1	Standardní vozík A2	Standardní vozík A1	Standardní vozík A2
3920	6468	81	162	33	182	33	182

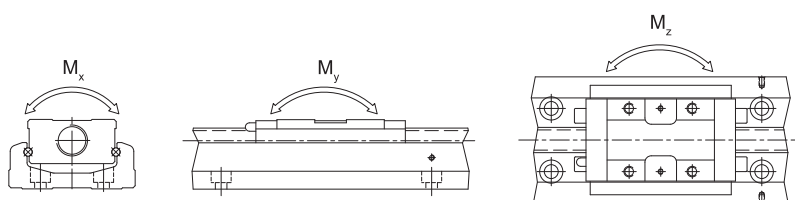

Modul bez krytování, standardní vozík

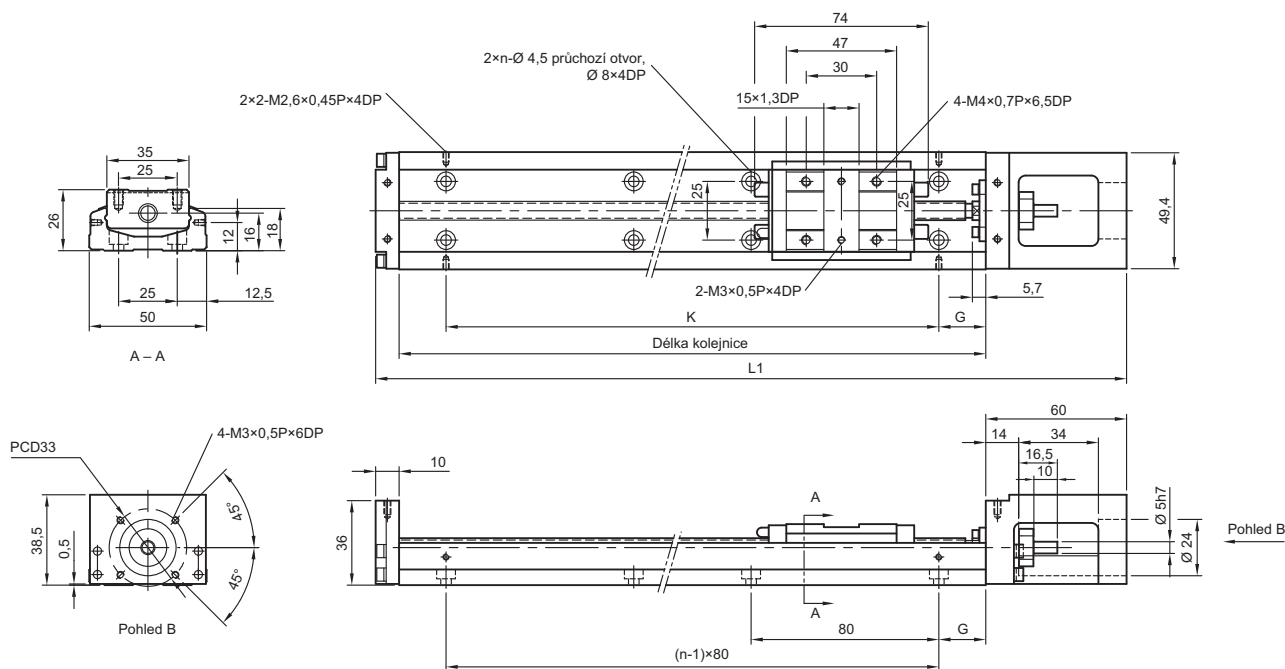

Rozměry [mm]														Hmotnost [kg]	
Délka pojezd. dráhy	Celková délka L1	Maximální zdvih		G	K	n	Kuličkový šroub				Rychlost [mm/s]		Vozík A1	Vozík A2	
		Vozík A1	Vozík A2				Jmenovitý průměr	Stoupání	Dynamická únosnost [N]	Statická únosnost [N]	Přesné	Normální			
150	220	70		35	80	2	8	2	2136	3489	270		1		
200	270	120	55	20	160	3	8	2	2136	3489	270		1,2	1,4	
250	320	170	105	45	160	3	8	2	2136	3489	270		1,4	1,6	
300	370	220	155	30	240	4	8	2	2136	3489	270		1,6	1,8	

Lineární vedení							
Únosnost [N]		Dovolený statický moment [Nm]					
Dynamická	Statická	M_x		M_y		M_z	
Standardní vozík A	Standardní vozík A	Standardní vozík A1	Standardní vozík A2	Standardní vozík A1	Standardní vozík A2	Standardní vozík A1	Standardní vozík A2
8700	12916	222	444	116	278	116	278

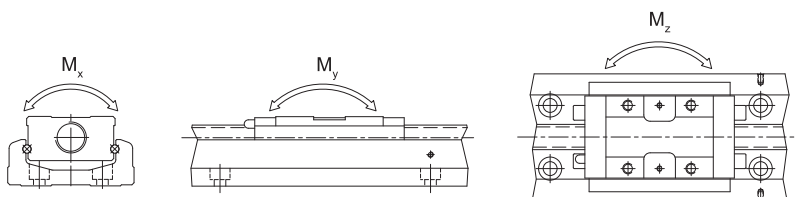

KK60 Lineární modul s kolej. vedením a kuličkovým šroubem

Modul bez krytování, standardní vozík

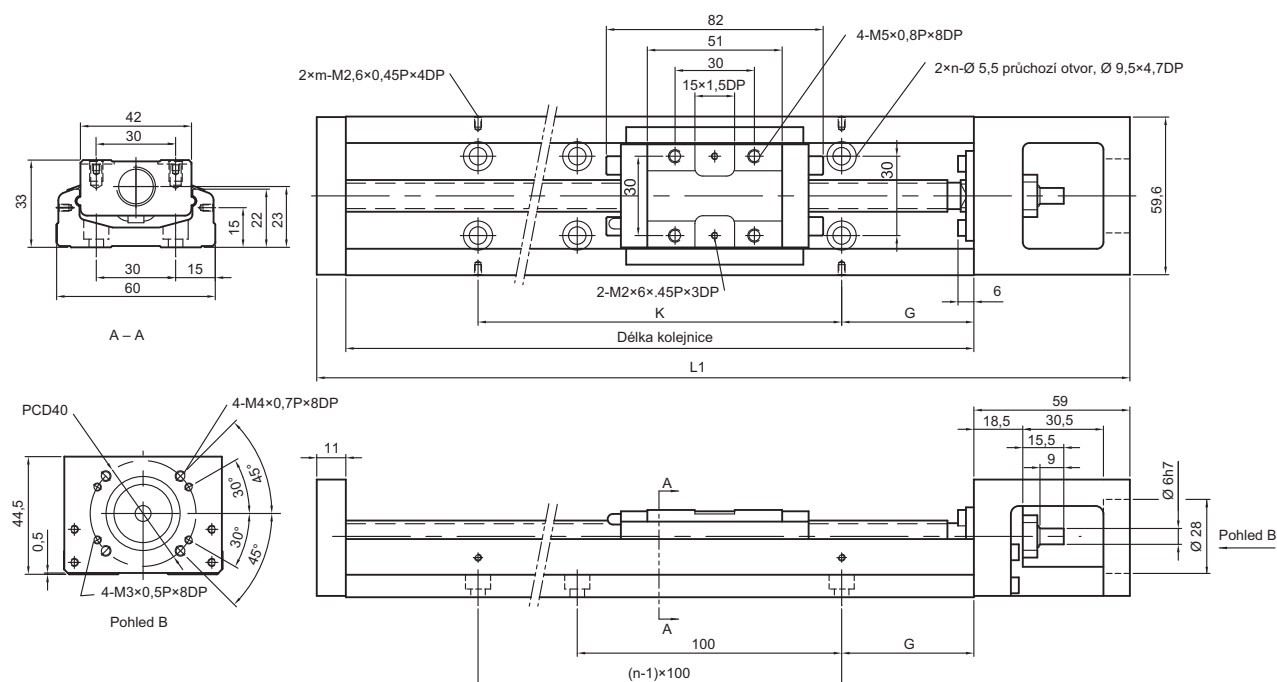

Rozměry [mm]														Hmotnost [kg]			
Délka pojezd. dráhy	Celková délka L1	Maximální zdvih		G	K	n	m	Kuličkový šroub				Rychlost [mm/s]		Vozík A1	Vozík A2		
		Vozík A1	Vozík A2					Jmenovitý průměr	Stoupání	Dynamická únosnost [N]		Statická únosnost [N]				Přesné	Normální
										P*	C**	P*	C**				
150	200	60		25	100	2	2	12	5	3744	3377	6243	5625	550	390	1,5	
									10	2410	2107	3743	3234	1100	790		
200	270	110		50	100	2	2	12	5	3744	3377	6243	5625	550	390	1,8	
									10	2410	2107	3743	3234	1100	790		
300	370	210	135	50	200	3	2	12	5	3744	3377	6243	5625	550	390	2,4	2,7
									10	2410	2107	3743	3234	1100	790		
400	470	310	235	50	100	4	4	12	5	3744	3377	6243	5625	550	390	3,0	3,3
									10	2410	2107	3743	3234	1100	790		
500	570	410	335	50	200	5	3	12	5	3744	3377	6243	5625	550	390	3,6	3,9
									10	2410	2107	3743	3234	1100	790		
600	670	510	435	50	100	6	6	12	5	3744	3377	6243	5625	340	340	4,2	4,6
									10	2410	2107	3743	3234	670	670		

Lineární vedení							
Únosnost [N]		Dovolený statický moment [Nm]					
Dynamická	Statická	M_x		M_y		M_z	
Standardní vozík A	Standardní vozík A	Standardní vozík A1	Standardní vozík A2	Standardní vozík A1	Standardní vozík A2	Standardní vozík A1	Standardní vozík A2
13230	21462	419	838	152	348	152	348

* Přesný KK modul.

** Normální KK modul.

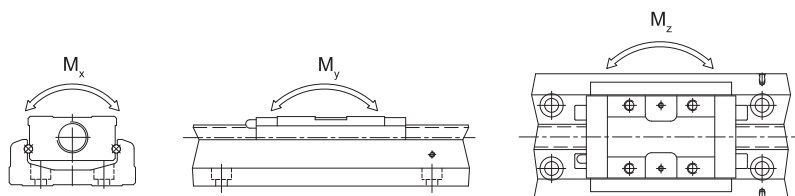

Tiskové chyby vyhrazeny. Obrázky mají informativní charakter.

Modul bez krytování, krátký vozík

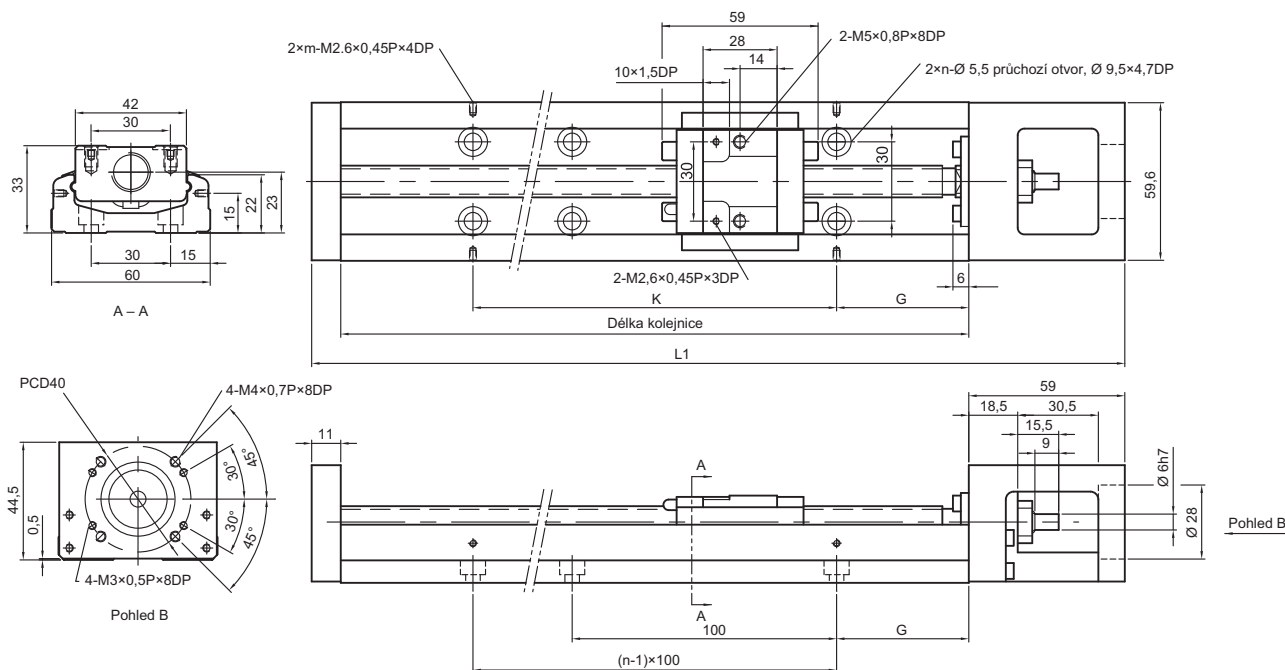

Rozměry [mm]														Hmotnost [kg]			
Délka pojezd. dráhy	Celková délka L1	Maximální zdvih		G	K	n	m	Kuličkový šroub				Rychlost [mm/s]		Vozík A1	Vozík A2		
		Vozík A1	Vozík A2					Jmenovitý průměr	Stoupání	Dynamická únosnost [N]		Statická únosnost [N]				Přesné	Normální
										P*	C**	P*	C**				
150	220	85	34	25	100	2	2	12	5	3744	3377	6243	5625	550	390	1,4	1,6
									10	2410	2107	3743	3234	1100	790		
200	270	135	84	50	100	2	2	12	5	3744	3377	6243	5625	550	390	1,7	1,9
									10	2410	2107	3743	3234	1100	790		
300	370	235	484	50	200	3	2	12	5	3744	3377	6243	5625	550	390	2,3	2,5
									10	2410	2107	3743	3234	1100	790		
400	470	335	284	50	100	4	4	12	5	3744	3377	6243	5625	550	390	2,9	3,1
									10	2410	2107	3743	3234	1100	790		
500	570	435	384	50	200	5	3	12	5	3744	3377	6243	5625	550	390	3,5	3,7
									10	2410	2107	3743	3234	1100	790		
600	670	535	484	50	100	6	6	12	5	3744	3377	6243	5625	340	340	4,1	4,3
									10	2410	2107	3743	3234	670	670		

Lineární vedení							
Únosnost [N]		Dovolený statický moment [Nm]					
Dynamická	Statická	M _x		M _y		M _z	
Krátký vozík S	Krátký vozík S	Krátký vozík S1	Krátký vozík S2	Krátký vozík S1	Krátký vozík S2	Krátký vozík S1	Krátký vozík S2
7173	11574	241	482	72	205	72	205

* Přesný KK modul.
** Normální KK modul.

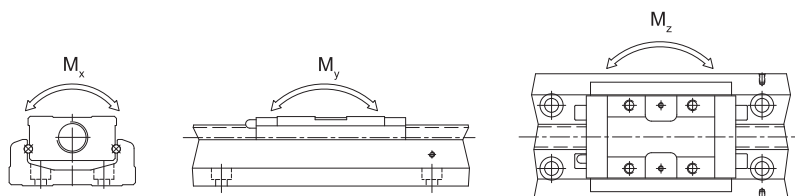

Tiskové chyby vyhrazeny. Obrázky mají informativní charakter.

KK86 Lineární modul s kolej. vedením a kuličkovým šroubem

Modul bez krytování, standardní vozík

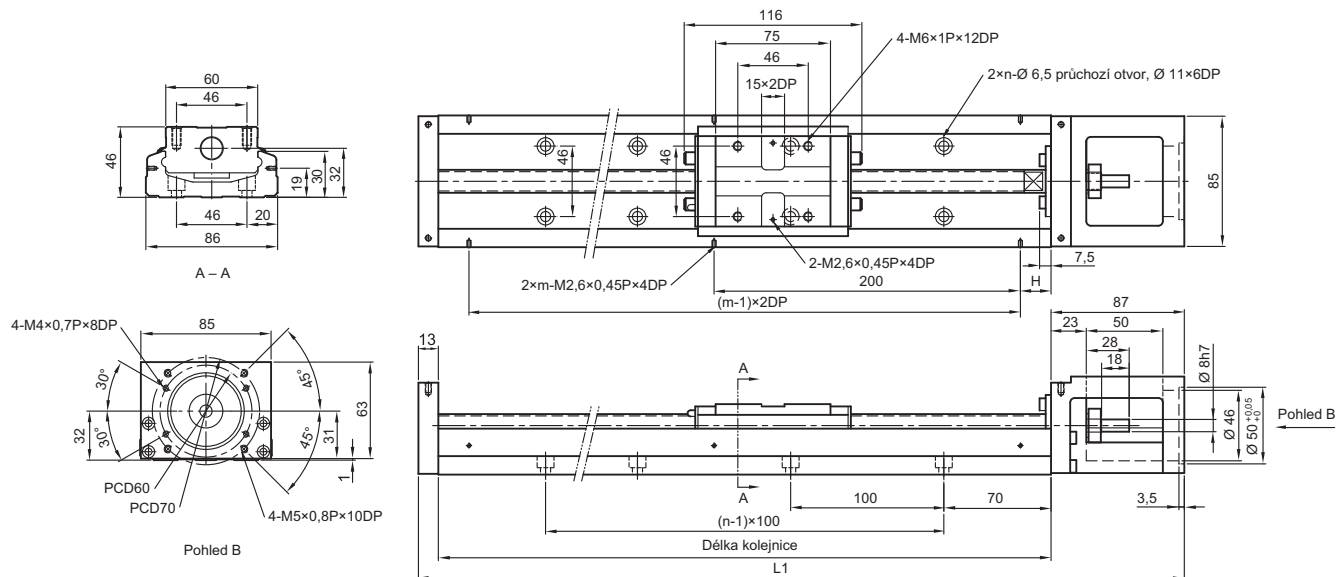

Rozměry [mm]														Hmotnost [kg]		
Délka pojezd. dráhy	Celková délka L1	Maximální zdvih		G	n	m	Kuličkový šroub				Rychlost [mm/s]		Vozík A1	Vozík A2		
		Vozík A1	Vozík A2				Jmenovitý průměr	Stoupání	Dynamická únosnost [N]		Statická únosnost [N]				Přesné	Normální
									P*	C**	P*	C**				
340	440	210	100	70	3	2	15	10	7144	6429	12642	11387	740	520	5,7	6,5
								20	4645	4175	7655	6889	1480	1050		
440	540	310	200	20	4	3	15	10	7144	6429	12642	11387	740	520	6,9	7,7
								20	4645	4175	7655	6889	1480	1050		
540	640	410	300	70	5	3	15	10	7144	6429	12642	11387	740	520	8,0	8,8
								20	4645	4175	7655	6889	1480	1050		
640	740	510	400	30	6	4	15	10	7144	6429	12642	11387	740	520	9,2	10,0
								20	4645	4175	7655	6889	1480	1050		
740	840	610	500	70	7	4	15	10	7144	6429	12642	11387	740	520	10,4	11,2
								20	4645	4175	7655	6889	1480	1050		
940	1040	810	700	70	9	5	15	10	7144	6429	12642	11387		430	11,6	12,4
								20	4645	4175	7655	6889		870		

Lineární vedení							
Únosnost [N]		Dovolený statický moment [Nm]					
Dynamická	Statická	M _x		M _y		M _z	
Standardní vozík A	Standardní vozík A	Standardní vozík A1	Standardní vozík A2	Standardní vozík A1	Standardní vozík A2	Standardní vozík A1	Standardní vozík A2
31458	50764	1507	3014	622	3050	622	3050

* Přesný KK modul.

** Normální KK modul.

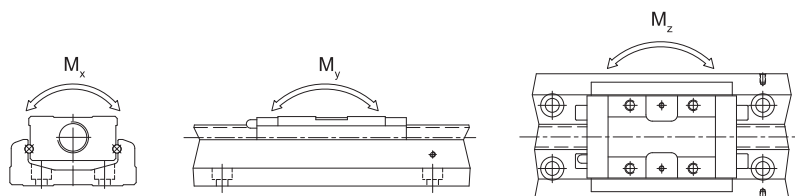

Tiskové chyby vyhrazeny. Obrázky mají informativní charakter.

Lineární modul s kolej. vedením a kuličkovým šroubem **KK100**

Modul bez krytování, standardní vozík

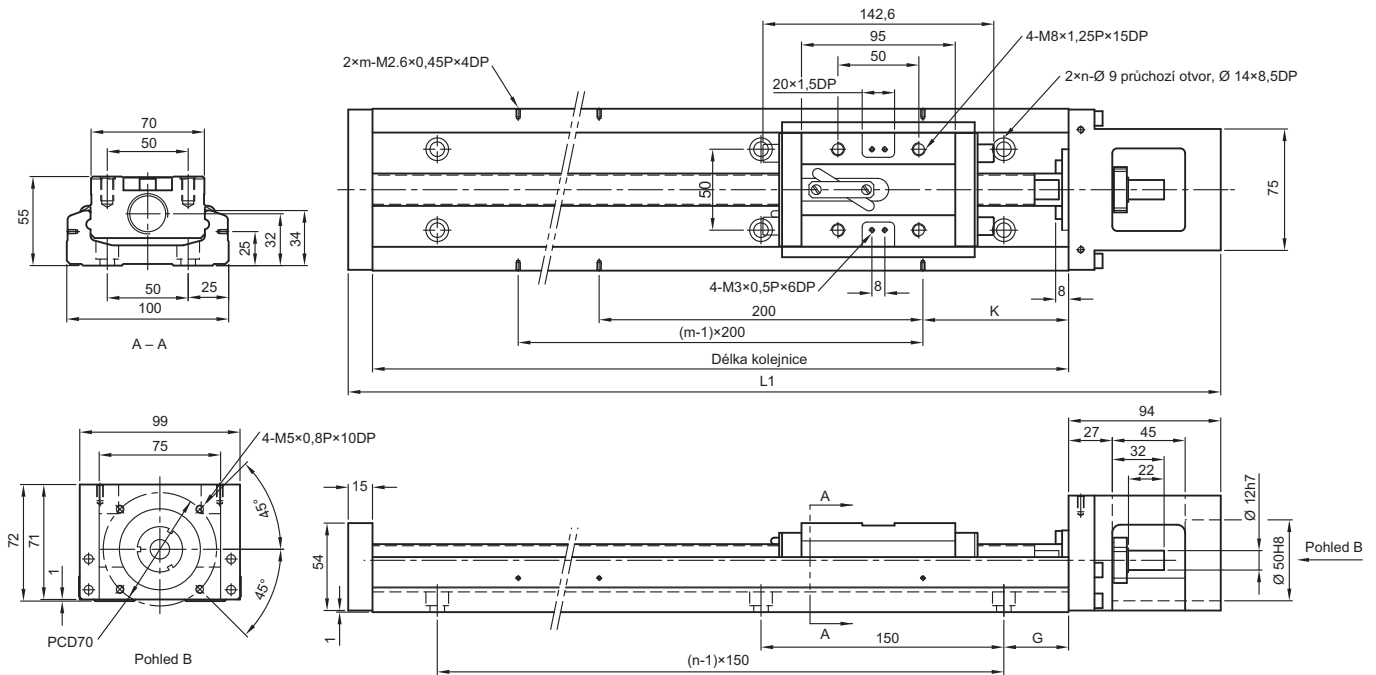

Rozměry [mm]															Hmotnost [kg]		
Délka pojezd. dráhy	Celková délka L1	Maximální zdvih		G	K	n	m	Kuličkový šroub				Rychlost [mm/s]		Vozík A1	Vozík A2		
		Vozík A1	Vozík A2					Jmenovitý průměr	Stoupání	Dynamická únosnost [N]		Statická únosnost [N]				Přesné	Normální
										P*	C**	P*	C**				
980	1089	828	700	40	90	7	5	20	20	7046	4782	12544	9163	1120		18,6	20,3
1080	1189	928	800	15	40	8	6	20	20	7046	4782	12544	9163	980		20,3	22,0
1180	1289	1028	900	65	90	8	6	20	20	7046	4782	12544	9163	750		22,0	23,7
1280	1389	1128	1000	40	40	9	7	20	20	7046	4782	12544	9163			23,6	25,3
1380	1489	1228	1100	15	90	10	7	20	20	7046	4782	12544	9163			25,3	27,0

Lineární vedení							
Únosnost [N]		Dovolený statický moment [Nm]					
Dynamická	Statická	M_x		M_y		M_z	
Standardní vozík A	Standardní vozík A	Standardní vozík A1	Standardní vozík A2	Standardní vozík A1	Standardní vozík A2	Standardní vozík A1	Standardní vozík A2
39200	63406	2205	4410	960	4763	960	4763

* Přesný KK modul.
 ** Normální KK modul.

